

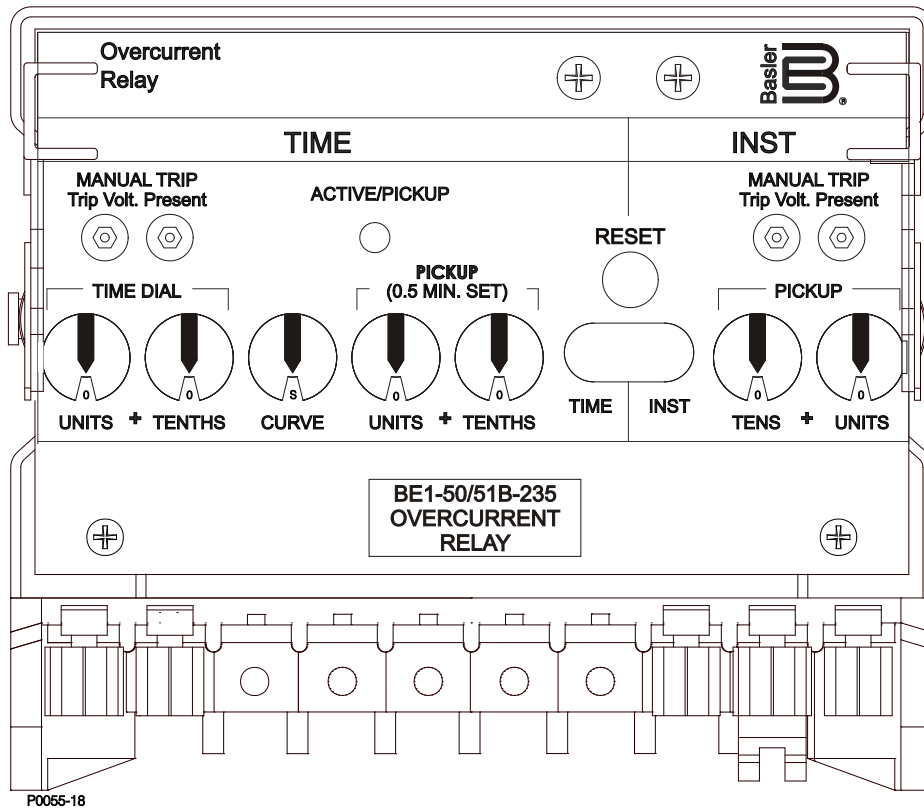



BE1-50/51B-235/-236

Overcurrent Relays

Instruction Manual



 **WARNING:** California's Proposition 65 requires special warnings for products that may contain chemicals known to the state of California to cause cancer, birth defects or other reproductive harm. Please note that by posting this Proposition 65 warning, we are notifying you that one or more of the Proposition 65 listed chemicals may be present in products we sell to you. For more information about the specific chemicals found in this product, please visit <https://www.basler.com/Prop65>.

Preface

This instruction manual provides information about the installation and operation of the BE1-50/51B-235/-236. To accomplish this, the following information is provided:

- General information and specifications
- Controls and indicators
- Functional description
- Installation and maintenance
- Testing

Conventions Used in this Manual

Important safety and procedural information is emphasized and presented in this manual through warning, caution, and note boxes. Each type is illustrated and defined as follows.

Warning!

Warning boxes call attention to conditions or actions that may cause personal injury or death.

Caution

Caution boxes call attention to operating conditions that may lead to equipment or property damage.

Note

Note boxes emphasize important information pertaining to installation or operation.



12570 State Route 143
Highland IL 62249-1074 USA

www.basler.com

info@basler.com

Tel: +1 618.654.2341

Fax: +1 618.654.2351

© 2026 by Basler Electric

All rights reserved

First printing: April 2008

Warning!

READ THIS MANUAL. Read this manual before installing, operating, or maintaining this equipment. Note all warnings, cautions, and notes in this manual as well as on the product. Keep this manual with the product for reference. Only qualified personnel should install, operate, or service this system. Failure to follow warning and cautionary labels may result in personal injury or property damage. Exercise caution at all times.

Basler Electric does not assume any responsibility to compliance or noncompliance with national code, local code, or any other applicable code. This manual serves as reference material that must be well understood prior to installation, operation, or maintenance.

For terms of service relating to this product and software, see the *Commercial Terms of Products and Services* document available at www.basler.com/terms.

This publication contains confidential information of Basler Electric Company, an Illinois corporation. It is loaned for confidential use, subject to return on request, and with the mutual understanding that it will not be used in any manner detrimental to the interests of Basler Electric Company and used strictly for the purpose intended.

It is not the intention of this manual to cover all details and variations in equipment, nor does this manual provide data for every possible contingency regarding installation or operation. The availability and design of all features and options are subject to modification without notice. Over time, improvements and revisions may be made to this publication. Before performing any of the following procedures, contact Basler Electric for the latest revision of this manual.

The English-language version of this manual serves as the only approved manual version.

Revision History

A historical summary of the changes made to this instruction manual is provided below. Revisions are listed in reverse chronological order.

Instruction Manual Revision History

Manual Revision and Date	Change
H, May 2026	<ul style="list-style-type: none"> Minor text edits.
G, Jan 2026	<ul style="list-style-type: none"> Minor text edits.
F, Mar 2025	<ul style="list-style-type: none"> Updated China RoHS table.
E, Nov 2024	<ul style="list-style-type: none"> Updated manual to reflect changes to main board. Updated burden data.
D, Feb 2024	<ul style="list-style-type: none"> Added China RoHS compliance. Minor text edits.
C, Dec 2019	<ul style="list-style-type: none"> Changed Instantaneous Element 50-A range to 1-99 Aac and added Note box about minimum current required to energize both instantaneous elements in Section 1. Updated Target Operate Current specifications. Added dotted-line box to demarcate components inside the BE1-50/51B from external components in Figure 4-2. Minor text edits throughout manual.
B1, Apr 2019	<ul style="list-style-type: none"> Added Prop 65 warning.
B, Mar 2011	<ul style="list-style-type: none"> Changed all references of ABB to Westinghouse. Added the year of the IEEE listings in Section 1. Removed references to case and connection plugs since these items are not supplied by Basler Electric.
A, Jan 2009	<ul style="list-style-type: none"> Removed notes about hard-wiring relay case to ground since relay is a direct replacement, i.e. not shipped with a case. Added GOST-R Certification in Section 1. Corrected terminal numbering in Figure 4-1, <i>Typical AC Connections</i>. Updated <i>Storage</i> statement in Section 4. Modified Figures 5-3 and 5-6, <i>Target Indicator Test Setup</i>. Minor text edits in Section 5.
—, Apr 2008	<ul style="list-style-type: none"> Initial release



Contents

Introduction	1-1
Controls and Indicators	2-1
Functional Description.....	3-1
Installation.....	4-1
Testing.....	5-1
Specifications.....	6-1
Time Characteristic Curves	7-1



1 • Introduction

BE1-50/51B-235 and BE1-50/51B-236 protective relays are direct replacements for ABB (Westinghouse) hereinafter referred to as ABB-type-CO relays. The BE1-50/51B-235 has a 5-ampere current sensing input. The BE1-50/51B-236 has a 1-ampere current sensing input. Compatible ABB model numbers are listed in Table 1-1.

Table 1-1. ABB Relays Suitable for Direct Replacement

ABB Catalog Number	Curve Type
CO-2*11*1N	Short Time
CO-5*11*1N	Long Time
CO-6*11*1N	Definite
CO-7*11*1N	Moderately Inverse
CO-8*11*1N	Inverse
CO-9*11*1N	Very Inverse
CO-11*11*1N	Extremely Inverse

* Any digit covering all pickup ranges except 50-Hz models.

To replace an existing ABB relay, perform the following steps.

1. Select the desired relay settings on your new BE1-50/51B-235 or BE1-50/51B-236 relay.
2. Remove the existing ABB relay cradle.
3. Insert the new relay cradle.
4. Close the knife-blade switches.
5. Install the new Basler Electric cover and secure with the captive thumbnut.

BE1-50/51B-235 and BE1-50/51B-236 relays are self-powered, compatible with 50- or 60-Hz power systems, and have three protection elements: one time overcurrent (51) element and two instantaneous overcurrent (50) elements. The 51 element offers timing characteristic curves similar to those used by CO relays.

Features

A wide range of pickup settings and front panel selectable time characteristics permit applications involving coordination with fuses, reclosers, cold load pickup, motor starting, and fixed time requirements. In addition, an integrating reset function is available to simulate the disk reset of electromechanical relays.

BE1-50/51B-235 and BE1-50/51B-236 overcurrent relays have the following standard features.

- Independent time and instantaneous elements
- A secure method to manually trip the breaker at the relay front panel
- Direct reading front panel controls
- Minimum pickup setting for safety during installation
- Time characteristics extend to a pickup multiple of 40
- Rugged draw-out construction
- Gravity-latching targets retain indication without power
- Built-in accuracy eliminates internal adjustments
- Minimum transient overreach
- Field-selectable characteristic curve selection similar to either GE-IAC- or ABB-CO-type curves
- Field-selectable instantaneous or integrating reset
- Field-selectable 50- or 60-Hz operation
- Field-selectable 0.0 or 0.1 second fixed instantaneous delay

Internal switches provide for selecting system-operating frequencies of 50 or 60 Hz, instantaneous element delays of 0.0 or 0.1 second, characteristic curve group selection for either GE-IAC- or ABB-CO-

type curves, and instantaneous or integrating reset characteristics. Switch location and description is provided in Section 2.

Advantages

BE1-50/51B-235 and BE1-50/51B-236 overcurrent relays have many advantages over other overcurrent relays. The primary advantages are:

- Time characteristics are defined by equations and graphs
- Field-selectable time characteristics
- Very low burden extends the linear range of the CTs
- Self-powered from the sensed current
- Continuous automatic calibration

BE1-50/51B-235 and BE1-50/51B-236 overcurrent relays may be tested without removing the relay from the case. Shorting contacts are provided for all current inputs when the relay chassis is removed from the relay case.

Table 2-1. Front Panel Controls and Indicators

Locator	Description		
A	<i>Instantaneous Overcurrent Manual Trip Jacks.</i> These jacks are used to manually trip a breaker controlled by the 50-A trip output contacts. This is achieved by plugging a jumper wire, terminated with two standard 0.08-inch diameter phone-tip plugs, into the two jacks. These jacks do not activate the 50-B trip output contacts.		
B	<p><i>Instantaneous Overcurrent A Pickup Selector Switches.</i> These two rotary switches select the instantaneous overcurrent A (50-A) pickup current setting in amperes (TENS and UNITS on the BE1-50/51B-235, COARSE and FINE on the BE1-50/51B-236). Adjusting these selector switches while the relay is in service may cause the relay to trip.</p> <table border="1" data-bbox="448 531 1305 709"> <thead> <tr> <th data-bbox="448 531 1305 590">Note</th> </tr> </thead> <tbody> <tr> <td data-bbox="448 590 1305 709">When testing time overcurrent functions, instantaneous pickup settings of 00 will affect the calibration of the time functions. Time pickup settings of 00 also affect instantaneous functions.</td> </tr> </tbody> </table>	Note	When testing time overcurrent functions, instantaneous pickup settings of 00 will affect the calibration of the time functions. Time pickup settings of 00 also affect instantaneous functions.
Note			
When testing time overcurrent functions, instantaneous pickup settings of 00 will affect the calibration of the time functions. Time pickup settings of 00 also affect instantaneous functions.			
C	<i>Target Indicators.</i> Red target indicators latch when the corresponding set of trip contacts closes and sufficient trip circuit current is detected. (The level of current that will trip each target indicator is jumper-selectable. See <i>Circuit Board Controls</i> for more information.) The Time target indicates the flow of current in the time overcurrent (51) trip circuit. The Inst target indicates the flow of current in the instantaneous overcurrent A (50-A) trip circuit. No target is provided for the instantaneous overcurrent B (50-B) trip circuit. Both target indicators are reset by pressing the target reset button (locator I).		
D	<i>Time Overcurrent Pickup Selector Switches.</i> These two rotary switches select the time overcurrent pickup current setting in amperes (UNITS and TENTHS on the BE1-50/51B-235, COARSE and FINE on the BE1-50/51B-236). Adjusting these selector switches while the relay is in service may cause the relay to trip.		
E	<i>Curve Selector Switch.</i> This ten-position rotary switch selects one of nine inverse timing characteristics or one fixed time function. Refer to Appendix A, <i>Characteristic Curves</i> for details about the timing characteristics of the BE1-50/51B-235 and BE1-50/51B-236.		
F	<i>Time Overcurrent Time Dial Selector Switches.</i> These two rotary switches select the desired curve of the timing characteristic selected by the Curve Selector Switch (locator E). When a fixed time characteristic is used (Curve Selector Switch setting of F), the setting of these switches corresponds to a time delay of 0.0 to 9.9 seconds.		
G	<i>Time Overcurrent Manual Trip Jacks.</i> These jacks are used to manually trip a breaker controlled by the 51 trip output contacts. This is achieved by plugging a jumper wire, terminated with two standard 0.08-inch diameter phone-tip plugs, into the two jacks.		
H	<i>Active/Pickup Indicator.</i> This bicolor LED indicates the level of current sensed by the relay. The LED is red when the sensed current exceeds the time overcurrent pickup setting. The LED color changes from red to green when the sensed current decreases below 95% of the time overcurrent pickup setting. A green LED indicates that the relay is active but not picked up.		
I	<i>Target Reset Button.</i> This button is pressed to reset the two, gravity-latched target indicators (locator C).		

Circuit Board Controls

Circuit board controls consist of two rotary selector switches, a slide switch, and two jumpers. Circuit board controls are illustrated in Figure 2-2 and described in Table 2-2. The locators and descriptions of Table 2-2 correspond to the locators shown in Figure 2-2.

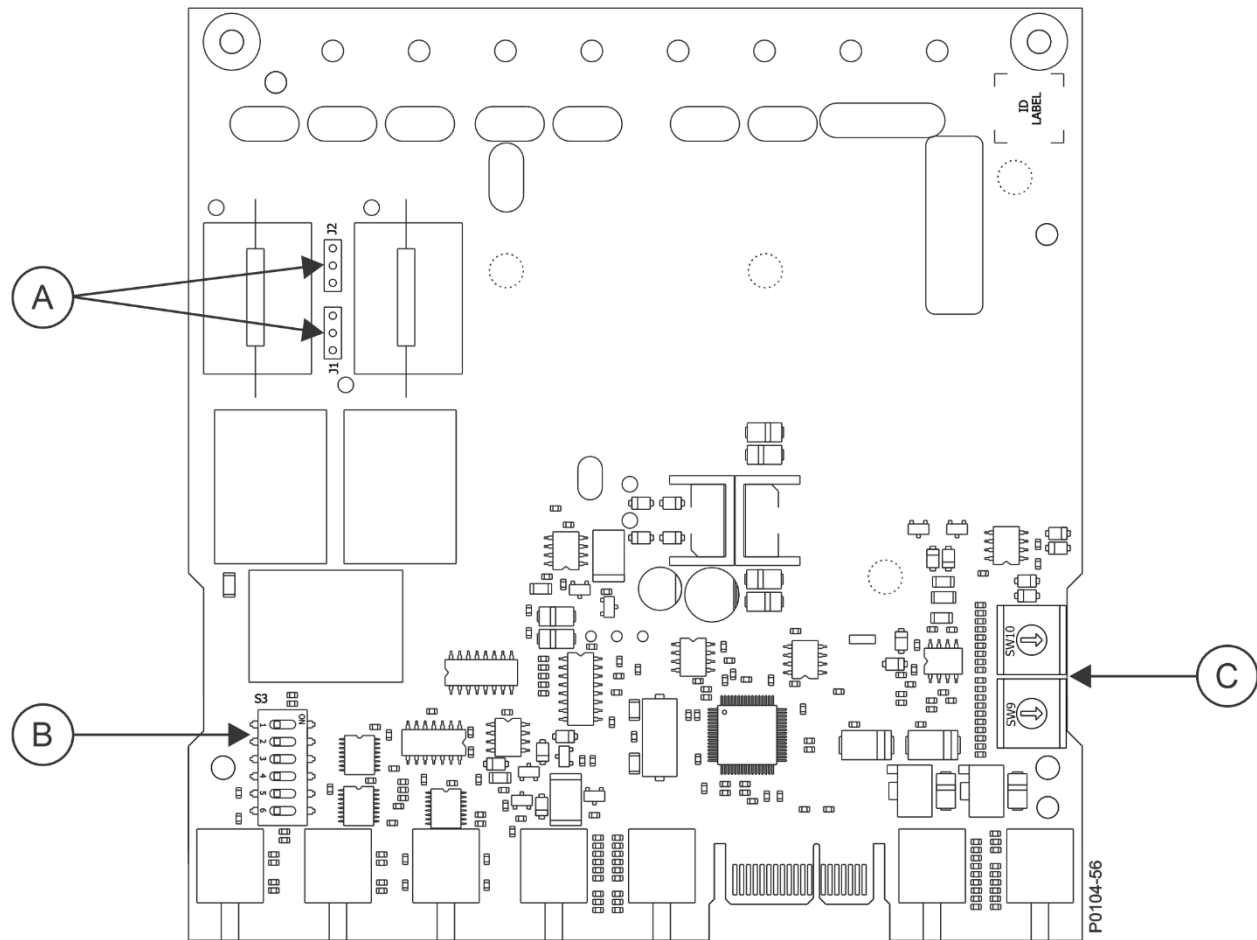

Figure 2-2. Circuit Board Controls

Table 2-2. Circuit Board Controls

Locator	Description
A	<p><i>Target Operating Current Jumpers.</i> Two user-adjustable jumpers control the range of trip circuit current required to operate the time overcurrent (51) and instantaneous overcurrent A (50-A) target indicators. Jumper J1 sets the minimum current range for the 50-A target indicator, and J2 sets the minimum current range for the 51 target indicator. Two jumper positions are possible: across pins 1 and 2 or across pins 2 and 3. Installing a jumper across pins 1 and 2 gives a minimum operating current of 0.9 to 2.25 A. Installing a jumper across pins 2 and 3 gives a minimum operating current of 80 to 200 mA.</p>
B	<p><i>Six-Position Slide Switch.</i> This switch assembly, designated SW3, has independent slide switches. Each switch functions as follows:</p> <p>SW3-1 selects the nominal system frequency. The OFF position selects 60-Hz operation and the ON position selects 50-Hz operation.</p> <p>SW3-2 provides an additional time delay for the instantaneous overcurrent A (50-A) element. The ON position provides an additional delay of 100 milliseconds.</p> <p>SW3-3 selects either GE-IAC- or ABB-CO-type characteristic curves. The ON position selects the GE-IAC-type curves (listed in Table 7-2) and the OFF position selects the ABB-CO-type curves (listed in Table 7-1).</p> <p>SW3-4 selects either an instantaneous or integrating time reset characteristic. The ON position selects an integrating reset characteristic and the OFF position selects an instantaneous reset characteristic.</p> <p>SW3-5 is not used.</p> <p>SW3-6 is not used.</p>
C	<p><i>Instantaneous Overcurrent B Pickup Selector Switches.</i> These two screwdriver-adjusted rotary switches select the instantaneous overcurrent B (50-B) pickup current setting in amperes.</p> <p>The 50-B pickup switches are accessed on the top side of the draw-out assembly by removing the draw-out assembly from the case.</p> <p><u>BE1-50/51B-235</u></p> <p>The left-hand switch (SW9) is a 16-position switch that sets the units portion (#.#) of the 50-B pickup setting in amperes. SW9 setting positions consist of 0 through 9 which correspond to values of 0 to 9 amperes and A through F which correspond to values of 10 to 15 amperes. The right-hand switch (SW10) is a 10-position switch that sets the tenths portion (#.#) of the 50-B pickup setting in amperes. SW10 setting positions consist of 0 through 9 which correspond to values of 0.0 to 0.9 amperes.</p> <p>The minimum allowable 50-B pickup setting is 1.0 Aac and the maximum allowable 50-B pickup setting is 15.9 Aac. Adjusting the 50-B pickup selector switches while the relay is in service may cause the relay to trip.</p> <p>Example: SW9 position 2 and SW10 position 5 is a setting of 2.5 Aac.</p> <p><u>BE1-50/51B-236</u></p> <p>The total pickup setting is the sum of two settings. The first setting, SW9 has a range of 0.2 to 3.0 corresponding to switch position 1 through F. The second setting, SW10 has a range of 0.02 to 0.18 corresponding to switch position 1 through 9.</p> <p>The minimum allowable 50-B pickup setting is 0.2 Aac and the maximum allowable 50-B pickup setting is 3.18 Aac. Adjusting the 50-B pickup selector switches while the relay is in service may cause the relay to trip.</p> <p>Example: SW9 position 2 and SW10 position 5 is a setting of 0.5 Aac.</p>

3 • Functional Description

This section illustrates and describes the functional capabilities of the BE1-50/51B-235 and BE1-50/51B-236 relays.

Function Block Descriptions

The function blocks of the BE1-50/51B-235 and BE1-50/51B-236 relays are illustrated in Figure 3-1 and described in the following paragraphs.

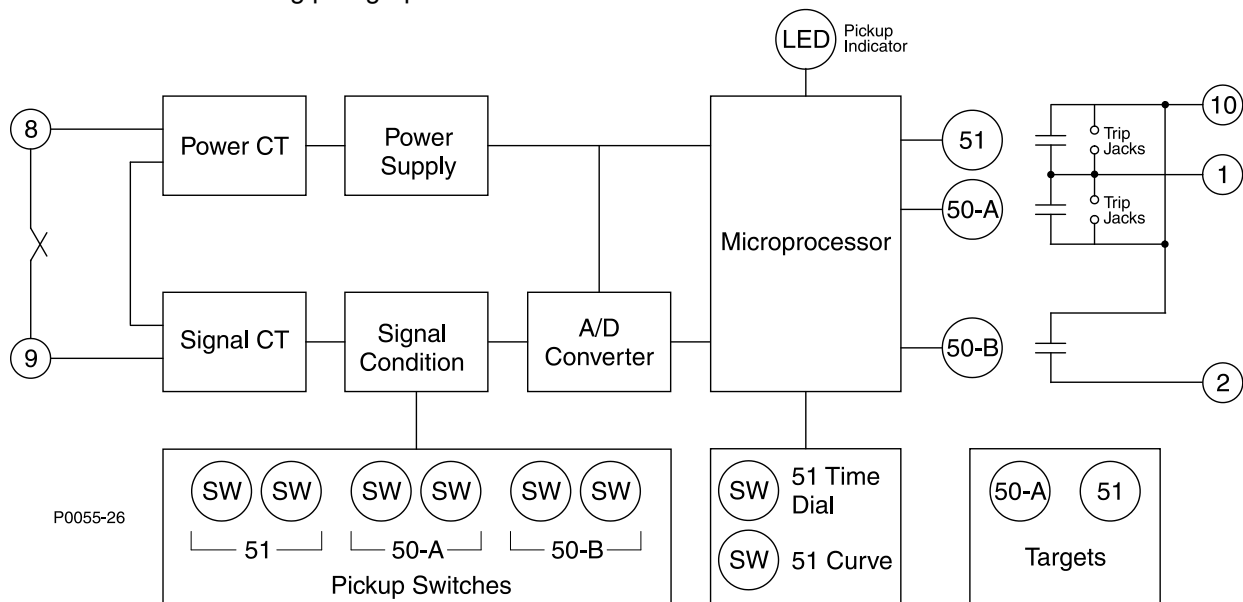

Figure 3-1. Function Block Diagram

Current Sensing Input

Single-phase ac current supplied by a system current transformer (CT) is applied to the BE1-50/51B-235 and BE1-50/51B-236 through terminals 8 and 9. Sensing current is applied to internal power and signal CTs.

Power CT and Power Supply

The output of the power CT is supplied to the power supply which provides rectified and filtered operating power for all relay circuitry. A precision 5 Vdc output of the power supply serves as a reference for automatic calibration.

Signal Conditioning

Current from the signal CT is rectified and applied to three independent sets of scaling resistors controlled by the Time Overcurrent (51), Instantaneous Overcurrent A (50-A), and Instantaneous Overcurrent B (50-B) pickup switches. The analog-to-digital converter receives the analog voltage developed across the scaling resistors and converts it into a digital signal that is supplied to the microprocessor.

Microprocessor

The microprocessor performs program operations based on the sensed current, switch settings, and the internal software program.

When sufficient current is sensed by the relay, the microprocessor is active and executing code, and the Active/Pickup LED is green. When the sensed current decreases below the operating threshold,

microprocessor operation is interrupted and the Active/Pickup LED turns off. A watchdog circuit resets the microprocessor program when code execution is interrupted.

Power-off sensing circuits measure the voltage across a capacitor at power-down and power-up. These circuits determine how long power has been removed based on the difference voltage and the circuit's RC time constant. This provides information from the integrating reset function even when power has been entirely removed.

The microprocessor performs the program operations based on the inputs and the internal software program. When the sensed current exceeds the TIME PICKUP setting, the ACTIVE/PICKUP LED turns from green to red. The 50-A/51 contact is closed in accordance with the TIME characteristic equation or if the sensed current exceeds the INST PICKUP setting. Likewise, sensed current exceeding the Instantaneous Overcurrent B Pickup selector switch setting causes the 50-B Trip output contacts to close.

Outputs

Each protective element (time overcurrent [51], instantaneous overcurrent A [50-A], and instantaneous overcurrent B [50-B]) is equipped with a set of normally-open contacts rated for tripping duty. A system circuit breaker controlled by the 51 or 50-A output contacts can be manually tripped by connecting a jumper across the Time Overcurrent Manual Trip jacks or the Instantaneous Overcurrent Manual Trip jacks. (Manual trip jacks are not provided for the system circuit breaker controlled by the 50-B output contacts.) Current flow in a trip circuit is indicated by operation of the corresponding target. The targets will not operate without adequate relay operating power.

Warning!

Trip circuit voltage is present at the front panel trip jacks. When shorting the trip jacks, use insulated jumpers to avoid contact with these voltages.

Target Indicators

Gravity-latched, manually-reset, current-operated target indicators are provided for the time overcurrent (51) trip output and the instantaneous overcurrent A (50-A) trip output. A target indicator is not provided for the 50-B trip output. The level of trip circuit current required to operate each target is individually controlled by a circuit board jumper. The minimum operating current range can be set for 80 to 200 milliamperes or 0.9 to 2.25 amperes. See Section 2, *Controls and Indicators* for jumper locations and function assignments.

4 • Installation

When not shipped as part of a control or switchgear panel, the relays are shipped in sturdy cartons to prevent damage during transit. Immediately upon receipt of a relay, check the model and part number against the requisition and packing list to see that they agree. Visually inspect the relay for damage that may have occurred during shipment. If there is evidence of damage, immediately file a claim with the carrier and notify the Regional Sales Office, or contact the Sales Representative at Basler Electric, Highland, Illinois.

Proper operation of the relay may be confirmed by performing the operational test procedure of Section 5. If the relay will not be installed immediately, store the relay in its original shipping carton in a moisture and dust-free environment.

Factory Settings

Factory settings for the internal switches of SW3 and jumper settings are as follows:

- SW3-1 — OFF (60-hertz operation).
- SW3-2 — OFF (0.0 additional fixed delay for the instantaneous element).
- SW3-3 — OFF (ABB-CO-type characteristic curves).
- SW3-4 — ON (Integrating reset characteristics).
- SW3-5 — Not used
- SW3-6 — Not used
- J1 pins 2-3 — 50-A minimum target operating current of 80 to 200 mA
- J2 pins 2-3 — 51 minimum target operating current of 80 to 200 mA

Installation

Select the desired relay settings before putting the relay into service. Changing pickup current settings while the relay is in service may cause tripping. Perform the following procedures to install the BE1-50/51B-235 or BE1-50/51B-236 relay.

- Select the desired relay settings on your new BE1-50/51B-235 or BE1-50/51B-236 relay.
- Remove the existing ABB relay cradle.
- Insert the new relay cradle and close the cradle latches locking the relay into the case.
- To install the cover, position the interlocking bracket at the top of the new Basler Electric cover into the mating receptacle at the top of the cover adapter plate. Secure the captive fastener at the bottom of the cover.

Connections

Typical ac and dc connections are shown in Figures 4-1 and 4-2.

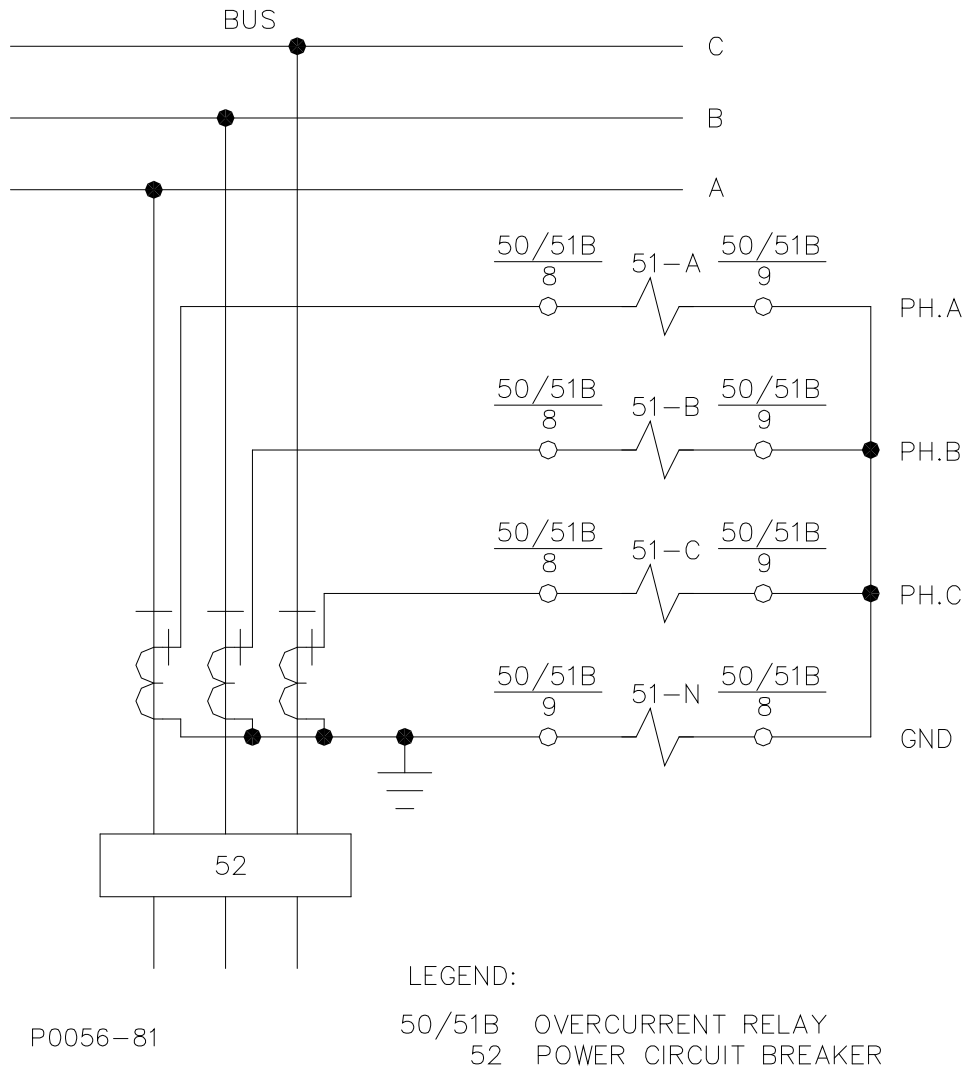

Figure 4-1. Typical AC Connections

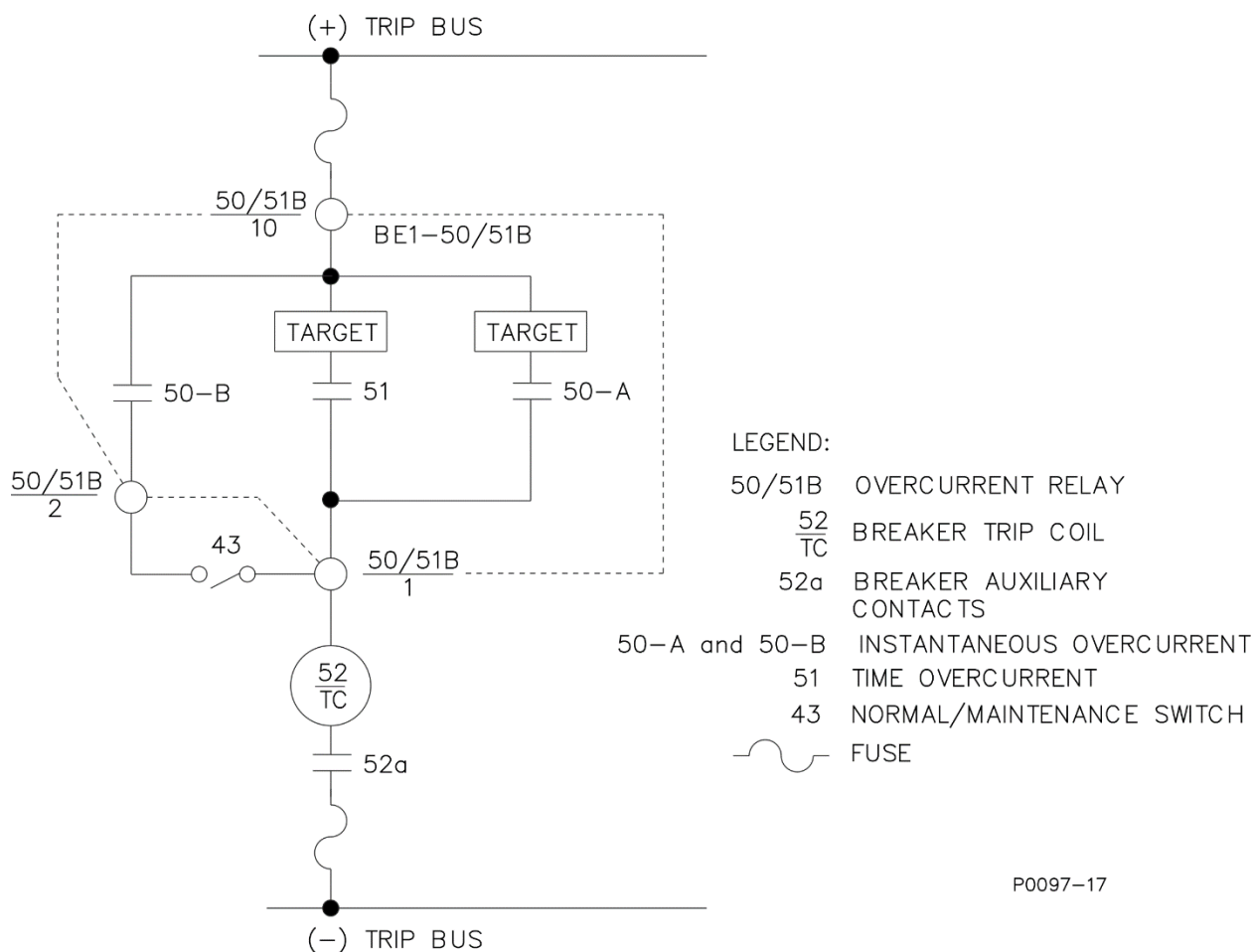

Figure 4-2. Typical DC Connections

Application Coordination

In a typical application coordination scheme, a BE1-50/51B-235 or BE1-50/51B-236 is used to provide primary protection for a radial distribution feeder. An electromechanical overcurrent relay with extremely inverse timing provides protection for the transformer and bus. To improve coordination with the electromechanical relay, the BE1-50/51B-235 or BE1-50/51B-236 is configured with the following settings:

- Integrating reset enabled (SW3-4 ON)
- ABB-CO-type curves selected (SW3-3 OFF)

The feeder reclosing relay is set for two reclose attempts at 3 and 15 seconds after the initial trip. If a permanent fault occurs (magnitude 10 times pickup), calculate the feeder breaker trip time for each of the three operations. Refer to Section 7 for the characteristic curve constants and definition of the terms used in the following time characteristic curve equations.

From the time characteristic curve equation:

$$T_T = \frac{AD}{M^N - C} + BD + K$$

$$= \frac{7.7624 \times 2}{10^{2.0938} - 1} + (0.02758 \times 2) + 0.028$$

$$= 0.209 \text{ seconds}$$

From the reset characteristic curve equation:

$$T_R = \frac{RD}{M^2 - 1}$$

M equals 0 if current goes to zero. A negative result indicates reset time.

$$= \frac{7.75 \times 2}{0^2 - 1} = -15.5 \text{ seconds}$$

Result: Full trip = 0.209 seconds and full reset = 15.5 seconds if current goes to zero.

In Figure 4-3:

T_A = 0.209 seconds (relay was at reset)

T_B = value < T_A because rewind has not gone to zero

T_C = value < T_A because rewind has not gone to zero

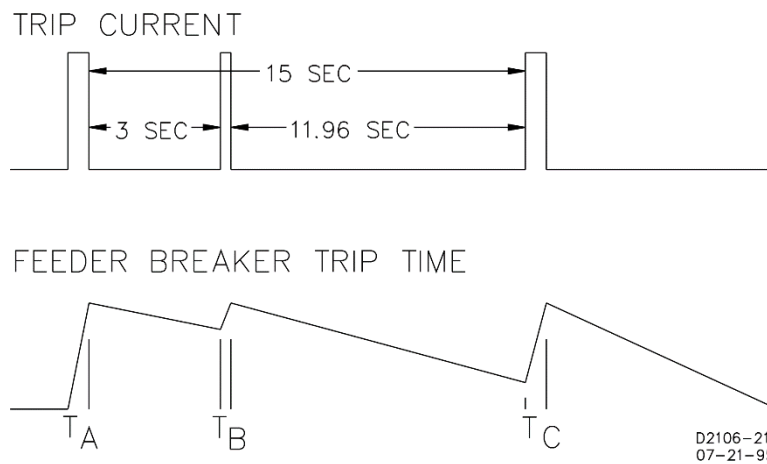

Figure 4-3. Coordination Timing Diagram

Maintenance

BE1-50/51B-235 and BE1-50/51B-236 relays require no preventative maintenance other than periodic checking of relay connections to make sure that they are clean and tight. If the relay fails to function properly, contact the Technical Sales Support department of Basler Electric.

Storage

This device contains long-life aluminum electrolytic capacitors. For devices that are not in service (spares in storage), the life of these capacitors can be maximized by energizing the device for 30 minutes once per year.

5 • Testing

Proper relay operation may be confirmed by performing the test procedures in this section.

Dielectric Test

In accordance with IEC 255-5 and IEEE C37.90-1989, one-minute dielectric (high potential) tests may be performed as follows:

- All circuits to cradle 2,828 Vdc or 2,000 Vac
- Input to output circuits 2,828 Vdc or 2,000 Vac

Output contacts are surge protected.

Test Procedures

The following test procedures verify operation of the BE1-50/51B-235 and BE1-50/51B-236 relays. The test setups illustrated in Figures 5-1 through 5-6 are intended primarily as an illustration of the principles involved. Other test equipment known to be capable of testing with the stated and implied tolerances (including equipment designed specifically for testing protective relays) may be used.

The minimum test equipment requirements are:

- Current source with a range of 0 to 20 Aac (sensing input current)
- AC or DC power source (target operation)
- Timer or counter

Notes

To ensure proper timing during testing, remove the current from the relay for R times D seconds. (Refer to the *Time Characteristic Curves* chapter for definitions of R and D.)

When testing TIME overcurrent functions, INST PICKUP settings of 00 will affect the calibration of the TIME functions. TIME PICKUP settings of 00 also affect INST functions.

Observe all applicable electrostatic discharge (ESD) precautions when handling the relay assembly.

Model BE1-50/51B-235 (Five-Ampere Sensing Input)

Time Overcurrent (51) Pickup

1. Connect and configure the relay for 51 pickup testing:
 - a. Connect the test setup shown in Figure 5-1.
 - b. Set circuit board switch SW3 as follows:
 - SW3-1 = ON for 50-Hz operation or OFF for 60-Hz operation
 - SW3-2 = OFF (no additional time delay for the 50-A element)
 - SW3-3 = OFF (ABB-CO-type characteristic curves)
 - SW3-4 = ON (integrating reset characteristic)
 - c. Set the TIME DIAL to 0.0.
 - d. Set CURVE to S.
 - e. Set TIME PICKUP to 0.5.

- f. Set INST PICKUP (50-A) to 90.
- g. Set INST PICKUP (50-B) (accessed at the top side of the assembly) to F0 (15.0 Aac).
2. Apply and increase current to terminals 8 and 9 until the Active/Pickup LED turns red. The applied current should be no greater than 0.55 Aac.
3. Decrease the applied current until the Active/Pickup LED changes from red to green and then off.
4. Set TIME PICKUP to 2.2.
5. Slowly increase current to terminals 8 and 9 until the Active/Pickup LED turns red. The applied current should be between 2.131 and 2.269 Aac.
6. Reduce the applied current to zero.

Time Dial

1. Connect and configure the relay for time dial testing:
 - a. Connect the test setup shown in Figure 5-1.
 - b. Set circuit board switch SW3 as follows:
 SW3-1 = ON for 50-Hz operation or OFF for 60-Hz operation
 SW3-2 = OFF (no additional time delay for the 50-A element)
 SW3-3 = OFF (ABB-CO-type characteristic curves)
 SW3-4 = ON (integrating reset characteristic)
 - c. Set TIME DIAL to 4.5.
 - d. Set CURVE to S.
 - e. Set TIME PICKUP to 1.0.
 - f. Set INST PICKUP (50-A) to 90.
 - g. Set INST PICKUP (50-B) (accessed at the top side of the assembly) to F0 (15.0 Aac).
2. Prepare to apply 1.5 Aac to terminals 8 and 9 and record the elapsed time from when current is applied until the 51 output contacts close.
3. Apply the current (step from 0 to 1.5 Aac) and record the elapsed time. The elapsed time should be between 0.345 and 0.424 seconds. (This tolerance is greater than $\pm 2\%$ because it is the accumulation of both pickup and timing tolerances.)
4. Remove the input current.

Integrating Reset

1. Connect and configure the relay for integrating reset testing.
 - a. Connect the test setup shown in Figure 5-1.
 - b. Set circuit board switch SW3 as follows:
 SW3-1 = ON for 50-Hz operation or OFF for 60-Hz operation
 SW3-2 = OFF (no additional time delay for the 50-A element)
 SW3-3 = OFF (ABB-CO-type characteristic curves)
 SW3-4 = ON (integrating reset characteristic)
 - c. Set TIME DIAL to 9.9
 - d. Set CURVE to V.
 - e. Set TIME PICKUP to 1.0.
 - f. Set INST PICKUP (50-A) to 90.
 - g. Set INST PICKUP (50-B) (accessed at the top side of the assembly) to F0 (15.0 Aac).
2. Apply 4.0 Aac to terminals 8 and 9. After the unit trips, remove the applied current for 29 ± 0.25 seconds, then reapply the current (4.0 Aac). Note the elapsed time from the reapplication of current to the second trip. The elapsed time should be 2.08 ± 0.4 seconds.

Instantaneous Overcurrent A (50-A) Pickup

1. Connect and configure the relay for 50-A pickup testing:
 - a. Connect the test setup shown in Figure 5-1.
 - b. Set circuit board switch SW3 as follows:
 SW3-1 = ON for 50-Hz operation or OFF for 60-Hz operation
 SW3-2 = OFF (no additional time delay for the 50-A element)
 SW3-3 = OFF (ABB-CO-type characteristic curves)
 SW3-4 = ON (integrating reset characteristic)
 - c. Set TIME DIAL to 0.0.
 - d. Set CURVE to S.
 - e. Set TIME PICKUP to 15.0.
 - f. Set INST PICKUP (50-A) to 02.
 - g. Set INST PICKUP (50-B) (accessed at the top side of the assembly) to F0 (15.0 Aac).
2. Apply and slowly increase current to terminals 8 and 9 until the 50-A output contacts close. The applied current should be between 1.935 and 2.065 Aac.
3. Decrease the applied current until the 50-A output contacts open.
4. Set INST PICKUP (50-A) to 08.
5. Slowly increase the current applied to terminals 8 and 9 until the 50-A output contacts close. The applied current should be between 7.815 and 8.185 Aac.
6. Reduce the applied current to zero.

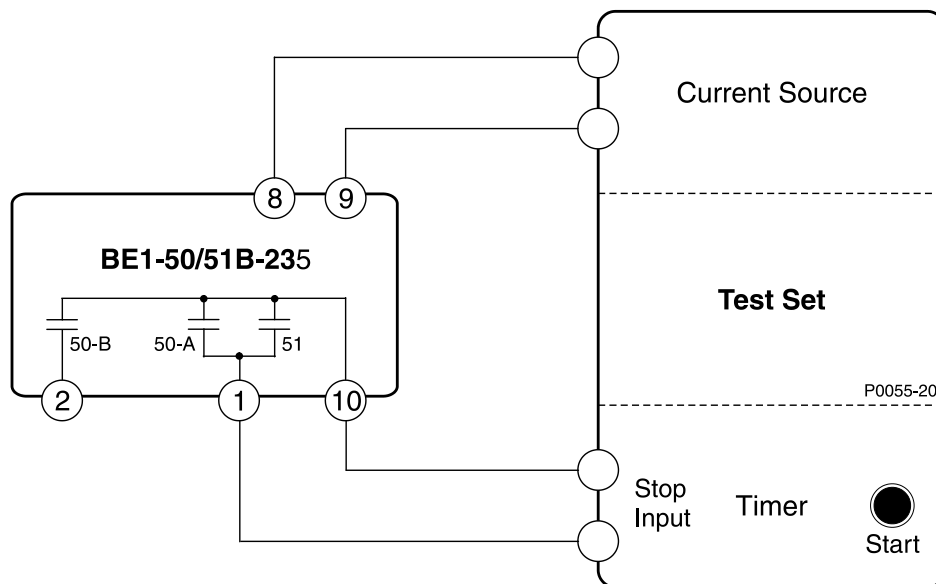

Figure 5-1. 51 Pickup, Time Dial, Integrating Reset, and 50-A Pickup Test Setup

Instantaneous Overcurrent B (50-B) Pickup

1. Connect and configure the relay for 50-B pickup testing:
 - a. Connect the test setup shown in Figure 5-2.
 - b. Set circuit board switch SW3 as follows:
 SW3-1 = ON for 50-Hz operation or OFF for 60-Hz operation
 SW3-2 = OFF (no additional time delay for the 50-A element)

- SW3-3 = OFF (ABB-CO-type characteristic curves)
 SW3-4 = ON (integrating reset characteristic)
- c. Set TIME DIAL to 0.0.
 - d. Set CURVE to S.
 - e. Set TIME PICKUP to 15.0.
 - f. Set INST PICKUP (50-A) to 90.
 - g. Set INST PICKUP (50-B) (accessed at the top side of the assembly) to 20 (2.0 Aac).
2. Apply and slowly increase current to terminals 8 and 9 until the 50-B output contacts close. The applied current should be between 1.935 and 2.065 Aac.
 3. Decrease the applied current until the 50-B output contacts open.
 4. Set INST PICKUP (50-B) to 80 (8.0 Aac).
 5. Slowly increase the current applied to terminals 8 and 9 until the 50-B output contacts close. The applied current should be between 7.815 and 8.185 Aac.
 6. Reduce the applied current to zero.

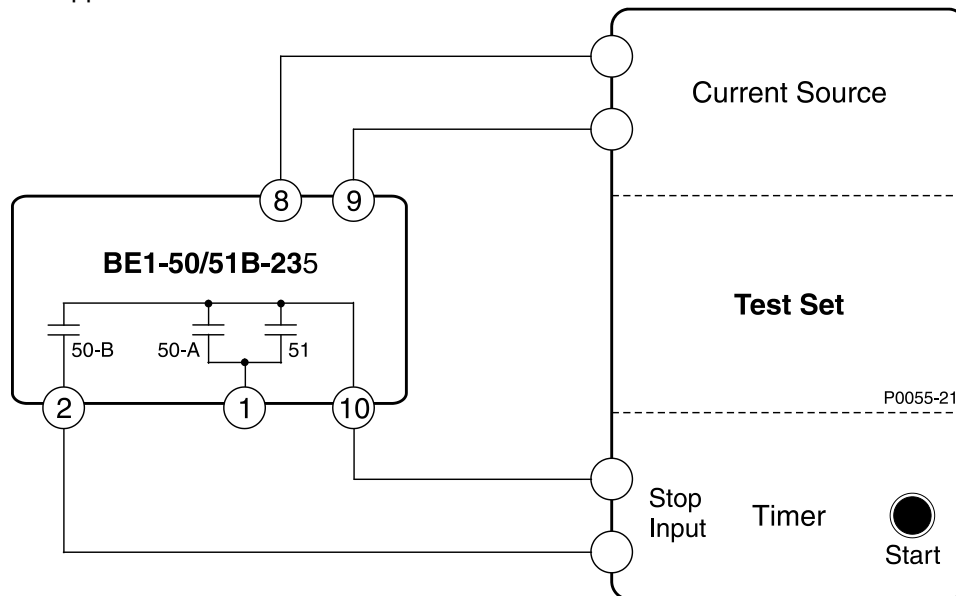

Figure 5-2. 50-B Pickup Test Setup

Target Indicators

1. Connect and configure the relay for target indicator testing:
 - a. Connect the test setup shown in Figure 5-3.
 - b. Set circuit board switch SW3 as follows:
 - SW3-1 = ON for 50-Hz operation or OFF for 60-Hz operation
 - SW3-2 = OFF (no additional time delay for the 50-A element)
 - SW3-3 = OFF (ABB-CO-type characteristic curves)
 - SW3-4 = ON (integrating reset characteristic)
 - c. Set TIME DIAL to 0.0.
 - d. Set CURVE to S.
 - e. Set TIME PICKUP to 1.0.
 - f. Set INST PICKUP (50-A) to 90.

- g. Set INST PICKUP (50-B) (accessed at the top side of the assembly) to F0 (15.0 Aac).
2. Apply 2 Aac to terminals 8 and 9 to trip the 51 relay output.
3. Slowly increase the power source to provide target current and verify that the Time target operates at the level of current determined by the Target Operating Current Jumpers.

The Target Operating Current Jumpers are located on the circuit board and identified as J1 and J2. J1 sets the minimum current range for the 50-A target and J2 sets the minimum current range for the 51 target. A jumper installed across pins 1 and 2 gives a minimum operating current of 0.9 to 2.25 A. A jumper installed across pins 2 and 3 gives a minimum operating current of 80 to 200 mA.

4. Remove the target and sensing current and reset the target.
5. Set TIME PICKUP to 9.0.
6. Set INST PICKUP (50-A) to 01.
7. Apply 2 Aac to terminals 8 and 9 to trip the 50-A relay output.
8. Slowly increase the power source to provide target current and verify that the Instantaneous target operates at the level of current determined by the Target Operating Current Jumpers.
9. Remove the target and sensing current and reset the target.

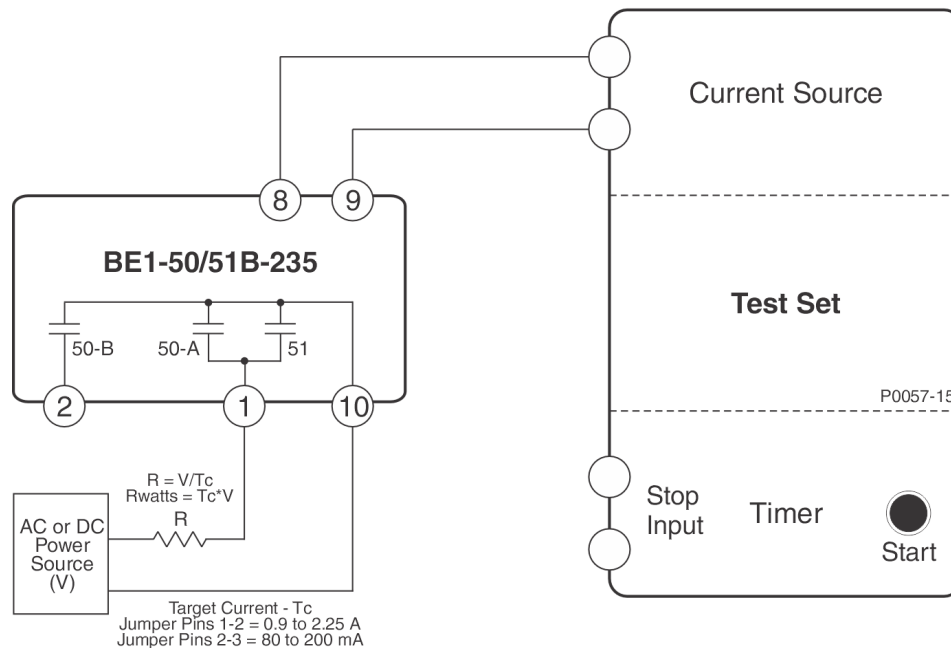

Figure 5-3. Target Indicator Test Setup

Manual Trip

1. Configure the relay for manual trip testing:
 - a. Connect the test setup as shown in Figure 5-1.
 - b. Set circuit board switch SW3 as follows:
 - SW3-1 = ON for 50-Hz operation or OFF for 60-Hz operation
 - SW3-2 = OFF (no additional time delay for the 50-A element)
 - SW3-3 = OFF (ABB-CO-type characteristic curves)
 - SW3-4 = ON (integrating reset characteristic)
 - c. Set TIME DIAL to 0.0
 - d. Set CURVE to S.

- e. Set TIME PICKUP to 1.0.
 - f. Set INST PICKUP (50-A) to 90.
 - g. Set INST PICKUP (50-B) (accessed at the top side of the assembly) to 20 (2.0 Aac).
2. Apply 0.9 Aac to terminals 8 and 9 (0.9 Aac provides relay operating power but is below the pickup threshold.)
 3. Connect a jumper to the Time Overcurrent Manual Trip jacks. Verify that the stop input of the test set timer recognizes a 51 contact closure.
 4. Remove the jumper and the current applied at relay terminals 8 and 9.
 5. Apply 0.9 Aac to terminals 8 and 9.
 6. Connect a jumper to the Instantaneous Overcurrent Manual Trip jacks. Verify that the stop input of the test set timer recognizes a 50-A contact closure
 7. Remove the jumper and the current applied to relay terminals 8 and 9.
 8. Reset targets.

Warning!

Trip circuit voltage is present at the front panel trip jacks. When shorting the trip jacks, use insulated jumpers to avoid contact with these voltages.

Model BE1-50/51B-236 (One-Ampere Sensing Input)

Time Overcurrent (51) Pickup

1. Connect and configure the relay for 51 pickup testing:
 - a. Connect the test setup shown in Figure 5-4.
 - b. Set circuit board switch SW3 as follows:
 - SW3-1 = ON for 50-Hz operation or OFF for 60-Hz operation
 - SW3-2 = OFF (no additional time delay for the 50-A element)
 - SW3-3 = OFF (ABB-CO-type characteristic curves)
 - SW3-4 = ON (integrating reset characteristic)
 - c. Set the TIME DIAL to 0.0.
 - d. Set CURVE to S.
 - e. Set TIME PICKUP to 0.1.
 - f. Set INST PICKUP (50-A) to 18.0.
 - g. Set INST PICKUP (50-B) (accessed at the top side of the assembly) to 30 (3.0 Aac).
2. Apply and increase current to terminals 8 and 9 until the Active/Pickup LED turns red. The applied current should be no greater than 0.11 Aac.
3. Decrease the applied current until the Active/Pickup LED changes from red to green and then off.
4. Set TIME PICKUP to 0.44.
5. Slowly increase current to terminals 8 and 9 until the Active/Pickup LED turns red. The applied current should be between 0.426 and 0.454 Aac.
6. Reduce the applied current to zero.

Time Dial

1. Connect and configure the relay for time dial testing:

- a. Connect the test setup shown in Figure 5-4.
 - b. Set circuit board switch SW3 as follows:
SW3-1 = ON for 50-Hz operation or OFF for 60-Hz operation
SW3-2 = OFF (no additional time delay for the 50-A element)
SW3-3 = OFF (ABB-CO-type characteristic curves)
SW3-4 = ON (integrating reset characteristic)
 - c. Set TIME DIAL to 4.5.
 - d. Set CURVE to S.
 - e. Set TIME PICKUP to 0.2.
 - f. Set INST PICKUP (50-A) to 18.0.
 - g. Set INST PICKUP (50-B) (accessed at the top side of the assembly) to F0 (3.0 Aac).
2. Prepare to apply 0.3 Aac to terminals 8 and 9 and record the elapsed time from when current is applied until the 51 output contacts close.
 3. Apply the current (step from 0 to 0.3 Aac) and record the elapsed time. The elapsed time should be between 0.345 and 0.424 seconds. (This tolerance is greater than $\pm 2\%$ because it is the accumulation of both pickup and timing tolerances.)
 4. Remove the input current.

Integrating Reset

1. Connect and configure the relay for integrating reset testing.
 - a. Connect the test setup shown in Figure 5-4.
 - b. Set circuit board switch SW3 as follows:
SW3-1 = ON for 50-Hz operation or OFF for 60-Hz operation
SW3-2 = OFF (no additional time delay for the 50-A element)
SW3-3 = OFF (ABB-CO-type characteristic curves)
SW3-4 = ON (integrating reset characteristic)
 - c. Set TIME DIAL to 9.9
 - d. Set CURVE to V.
 - e. Set TIME PICKUP to 0.2.
 - f. Set INST PICKUP (50-A) to 18.0.
 - g. Set INST PICKUP (50-B) (accessed at the top side of the assembly) to F0 (3.0 Aac).
2. Apply 0.8 Aac to terminals 8 and 9. After the unit trips, remove the applied current for 29 ± 0.25 seconds, then reapply the current (0.8 Aac). Note the elapsed time from the reapplication of current to the second trip. The elapsed time should be 2.08 ± 0.4 seconds.

Instantaneous Overcurrent A (50-A) Pickup

1. Connect and configure the relay for 50-A pickup testing:
 - a. Connect the test setup shown in Figure 5-4.
 - b. Set circuit board switch SW3 as follows:
SW3-1 = ON for 50-Hz operation or OFF for 60-Hz operation
SW3-2 = OFF (no additional time delay for the 50-A element)
SW3-3 = OFF (ABB-CO-type characteristic curves)
SW3-4 = ON (integrating reset characteristic)
 - c. Set TIME DIAL to 0.0.
 - d. Set CURVE to S.
 - e. Set TIME PICKUP to 3.18.

- f. Set INST PICKUP (50-A) to 0.4.
- g. Set INST PICKUP (50-B) (accessed at the top side of the assembly) to F0 (3.0 Aac).
2. Apply and slowly increase current to terminals 8 and 9 until the 50-A output contacts close. The applied current should be between 0.387 and 0.413 Aac.
3. Decrease the applied current until the 50-A output contacts open.
4. Set INST PICKUP (50-A) to 1.6.
5. Slowly increase the current applied to terminals 8 and 9 until the 50-A output contacts close. The applied current should be between 1.563 and 1.637 Aac.
6. Reduce the applied current to zero.

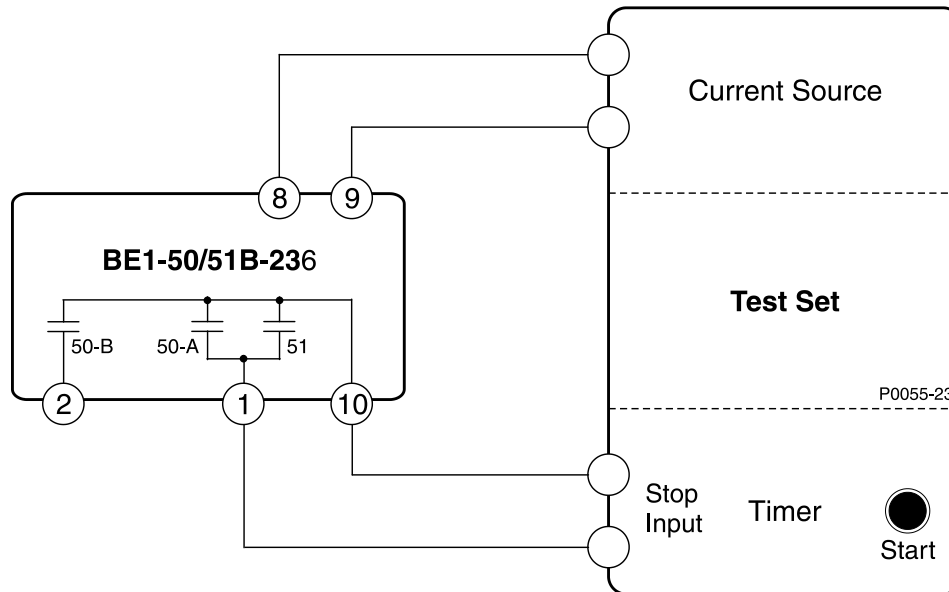

Figure 5-4. 51 Pickup, Time Dial, Integrating Reset, and 50-A Pickup Test Setup

Instantaneous Overcurrent B (50-B) Pickup

1. Connect and configure the relay for 50-B pickup testing:
 - a. Connect the test setup shown in Figure 5-5.
 - b. Set circuit board switch SW3 as follows:
 - SW3-1 = ON for 50-Hz operation or OFF for 60-Hz operation
 - SW3-2 = OFF (no additional time delay for the 50-A element)
 - SW3-3 = OFF (ABB-CO-type characteristic curves)
 - SW3-4 = ON (integrating reset characteristic)
 - c. Set TIME DIAL to 0.0.
 - d. Set CURVE to S.
 - e. Set TIME PICKUP to 3.18.
 - f. Set INST PICKUP (50-A) to 18.0.
 - g. Set INST PICKUP (50-B) (accessed at the top side of the assembly) to 20 (0.4 Aac).
2. Apply and slowly increase current to terminals 8 and 9 until the 50-B output contacts close. The applied current should be between 0.387 and 0.413 Aac.
3. Decrease the applied current until the 50-B output contacts open.
4. Set INST PICKUP (50-B) to 80 (1.6 Aac).

5. Slowly increase the current applied to terminals 8 and 9 until the 50-B output contacts close. The applied current should be between 1.563 and 1.637 Aac.
6. Reduce the applied current to zero.

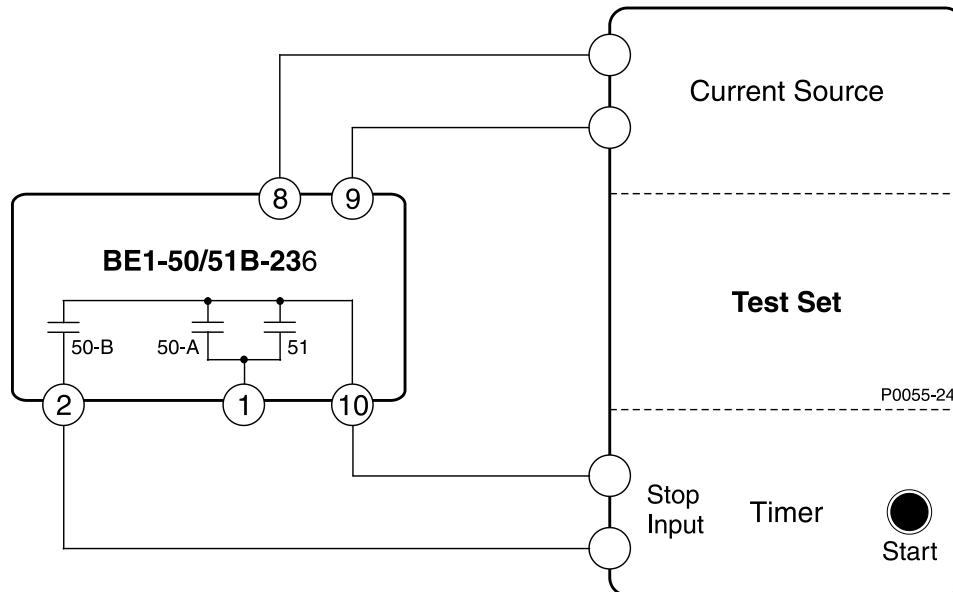

Figure 5-5. 50-B Pickup Test Setup

Target Indicators

1. Connect and configure the relay for target indicator testing:
 - a. Connect the test setup shown in Figure 5-6.
 - b. Set circuit board switch SW3 as follows:
 SW3-1 = ON for 50-Hz operation or OFF for 60-Hz operation
 SW3-2 = OFF (no additional time delay for the 50-A element)
 SW3-3 = OFF (ABB-CO-type characteristic curves)
 SW3-4 = ON (integrating reset characteristic)
 - c. Set TIME DIAL to 0.0.
 - d. Set CURVE to S.
 - e. Set TIME PICKUP to 0.2.
 - f. Set INST PICKUP (50-A) to 18.0.
 - g. Set INST PICKUP (50-B) (accessed at the top side of the assembly) at F0 (3.0 Aac).
2. Apply 0.4 Aac to terminals 8 and 9 to trip the 51 relay output.
3. Slowly increase the power source to provide target current and verify that the Time target operates at the level of current determined by the Target Operating Current Jumpers.
 The Target Operating Current Jumpers are located on the circuit board and identified as J1 and J2. J1 sets the minimum current range for the 50-A target and J2 sets the minimum current range for the 51 target. A jumper installed across pins 1 and 2 gives a minimum operating current of 0.9 to 2.25 A. A jumper installed across pins 2 and 3 gives a minimum operating current of 80 to 200 mA.
4. Remove the target and sensing current and reset the target.
5. Set TIME PICKUP to 1.8.
6. Set INST PICKUP (50-A) to 0.2.
7. Apply 0.4 Aac to terminals 8 and 9 to trip the 50-A relay output.

8. Slowly increase the power source to provide target current and verify that the Instantaneous target operates at the level of current determined by the Target Operating Current Jumpers.
9. Remove the target and sensing current and reset the targets.

Warning!

Trip circuit voltage is present at the front panel test points. When shorting the test points, use insulated jumpers to avoid contact with these voltages.

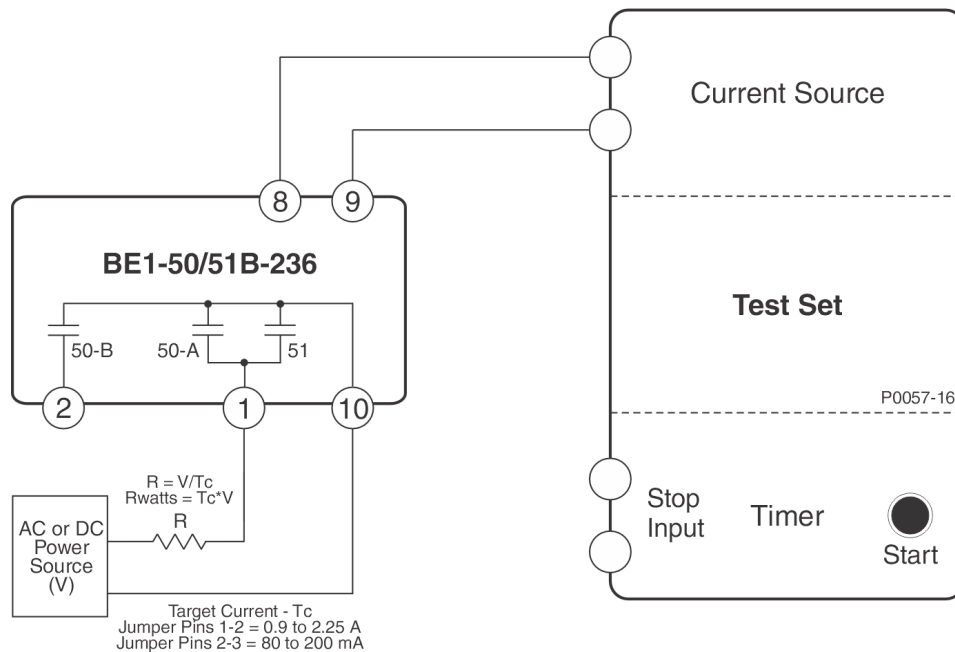

Figure 5-6. Target Indicator Test Setup

Manual Trip

1. Configure the relay for manual trip testing:
 - a. Connect the test setup as shown in Figure 5-4.
 - b. Set circuit board switch SW3 as follows:
 - SW3-1 = ON for 50-Hz operation or OFF for 60-Hz operation
 - SW3-2 = OFF (no additional time delay for the 50-A element)
 - SW3-3 = OFF (ABB-CO-type characteristic curves)
 - SW3-4 = ON (integrating reset characteristic)
 - c. Set TIME DIAL to 0.0
 - d. Set CURVE to S.
 - e. Set TIME PICKUP to 0.2.
 - f. Set INST PICKUP (50-A) to 18.0.
 - g. Set INST PICKUP (50-B) (accessed at the top side of the assembly) at 20 (0.4 Aac).

2. Apply 0.18 Aac to terminals 8 and 9 (0.18 Aac provides relay operating power but is below the pickup threshold.)
3. Connect a jumper to the Time Overcurrent Manual Trip jacks. Verify that the stop input of the test set timer recognizes a 51 contact closure.
4. Remove the jumper and the current applied at relay terminals 8 and 9.
5. Apply 0.18 Aac to terminals 8 and 9.
6. Connect a jumper to the Instantaneous Overcurrent Manual Trip jacks. Verify that the stop input of the test set timer recognizes a 50-A contact closure
7. Remove the jumper and the current applied to relay terminals 8 and 9.
8. Reset targets.



6 • Specifications

BE1-50/51B-235 and BE1-50/51B-236 electrical and physical specifications are listed in the following paragraphs.

Time Overcurrent (51) Element

BE1-50/51B-235 Pickup

Setting Range 0.5 to 15.9 Aac
 Setting Increment 0.1 Aac
 Accuracy Sum of $\pm 2\%$ and ± 25 mAac

BE1-50/51B-236 Pickup

Setting Range 0.1 to 3.18 Aac
 Setting Increment 0.02 Aac
 Accuracy Sum of $\pm 2\%$ and ± 5 mAac

Dropout

Dropout occurs at 95% of pickup value.

Characteristic Curves

Available curve types follow IEEE Standard C37.112 (1996) and emulate standard GE IAC, ABB CO, and BS142 curves. Section 7, *Time Characteristic Curves* illustrates the available curves and lists the applicable constants.

Curve Types Short Inverse, Long Inverse, Definite Time, Moderately Inverse, Inverse, Very Inverse, Extremely Inverse, BS142 Very Inverse, BS142 Extremely Inverse, Fixed Time
 Time Multiplier 11 curves for each characteristic
 Timing Accuracy The sum of ± 1 cycle and $\pm 2\%$ for the range of 2 to 40 times tap and is for a given measured multiple of tap. The timing accuracy is the sum of ± 2 cycles and $\pm 2\%$ for the range of 1.3 to 2 times tap and is for a given measured multiple of tap.

Fixed Timing

Setting Range 0.1 to 9.9 s
 Setting Increment 0.1 s

Reset

Integrating Simulates the disk reset of electromechanical relays and begins when the current decreases below 95% of pickup. Section 7, *Time Characteristic Curves* illustrates the integrating reset characteristic curve and equation.

Instantaneous Reset occurs when current decreases to 95% of the pickup level.

Instantaneous Overcurrent A (50-A) Element

Note

At least 2 A (5 A styles) or 0.4 A (1 A styles) is required to energize both instantaneous elements at the same time. Therefore, only one instantaneous element can be set below 2 A (5 A styles) or 0.4 A (1 A styles).

BE1-50/51B-235 Pickup

Setting Range 1 to 99 Aac
 Setting increment 1 Aac
 Accuracy..... Sum of $\pm 2\%$ and ± 25 mAac

BE1-50/51B-236 Pickup

Setting Range 0.4 to 19.8 Aac
 Setting increment 0.2 Aac
 Accuracy..... Sum of $\pm 2\%$ and ± 5 mAac

Dropout

Dropout occurs at 95% of pickup value.

Time Delay

Switch selectable—no intentional delay (SW3-2 OFF) or a fixed delay of 100 ms (SW3-2 ON). Section 7, *Time Characteristic Curves* illustrates the characteristic curve for the 50-A and 50-B elements.

Instantaneous Overcurrent B (50-B) Element**Note**

At least 2 A (5 A styles) or 0.4 A (1 A styles) is required to energize both instantaneous elements at the same time. Therefore, only one instantaneous element can be set below 2 A (5 A styles) or 0.4 A (1 A styles).

BE1-50/51B-235 Pickup

Setting Range 1 to 15.9 Aac
 Setting increment 0.1 Aac
 Accuracy..... Sum of $\pm 2\%$ and ± 25 mAac

BE1-50/51B-236 Pickup

Setting Range 0.2 to 3.18 Aac
 Setting increment 0.02 Aac
 Accuracy..... Sum of $\pm 2\%$ and ± 5 mAac

Dropout

Dropout occurs at 95% of pickup value.

Time Delay

Fixed at no intentional delay. Section 7, *Time Characteristic Curves* illustrates the characteristic curve for the 50-A and 50-B elements.

Reset Characteristic

Resets within 16 ms of when sensed current decreases below the pickup level.

Current Sensing InputBE1-50/51B-235

Continuous Rating..... 14 Aac*
 1 Second Rating..... 400 Aac

* Continuous rating is 14 Aac for temperatures up to 45°C. See Figure 6-1 for derating curve.

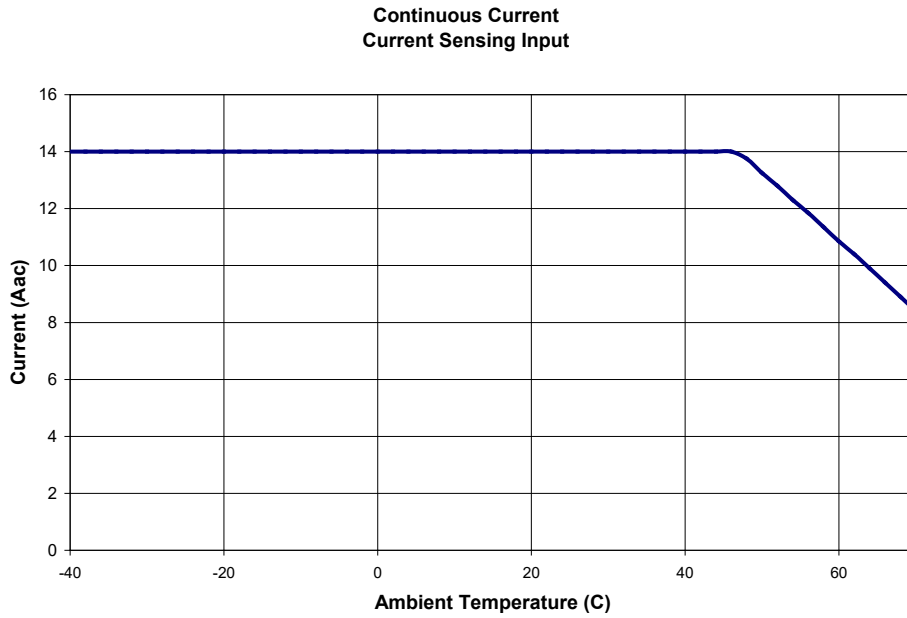

Figure 6-1. Current Sensing Input Derating Curve (BE1-50/51B-235)

BE1-50/51B-236

Continuous Rating.....2.8 Aac*

1 Second Rating.....80 Aac

* Continuous rating is 2.8 Aac for temperatures up to 45°C. See Figure 6-2 for derating curve.

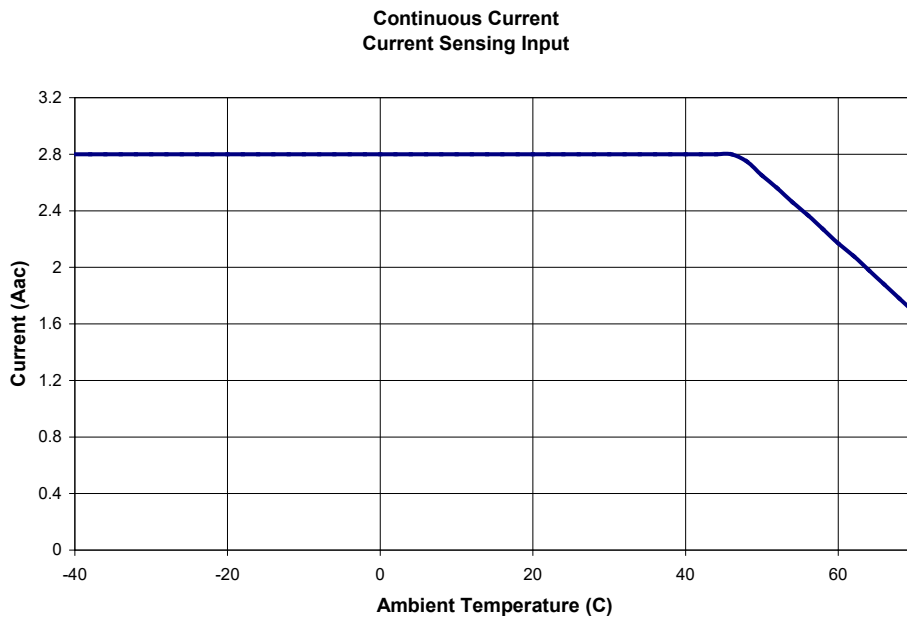

Figure 6-2. Current Sensing Input Derating Curve (BE1-50/51B-236)

Burden

Burden is non-linear. Figure 6-3 illustrates the device burden.

1-Ampere Unit

0.1 ampere $Z = 110 \Omega$

1.0 ampere $Z = 6 \Omega$

5-Ampere Unit

0.5 amperes $Z = 4.4 \Omega$

5.0 amperes $Z = 0.2 \Omega$

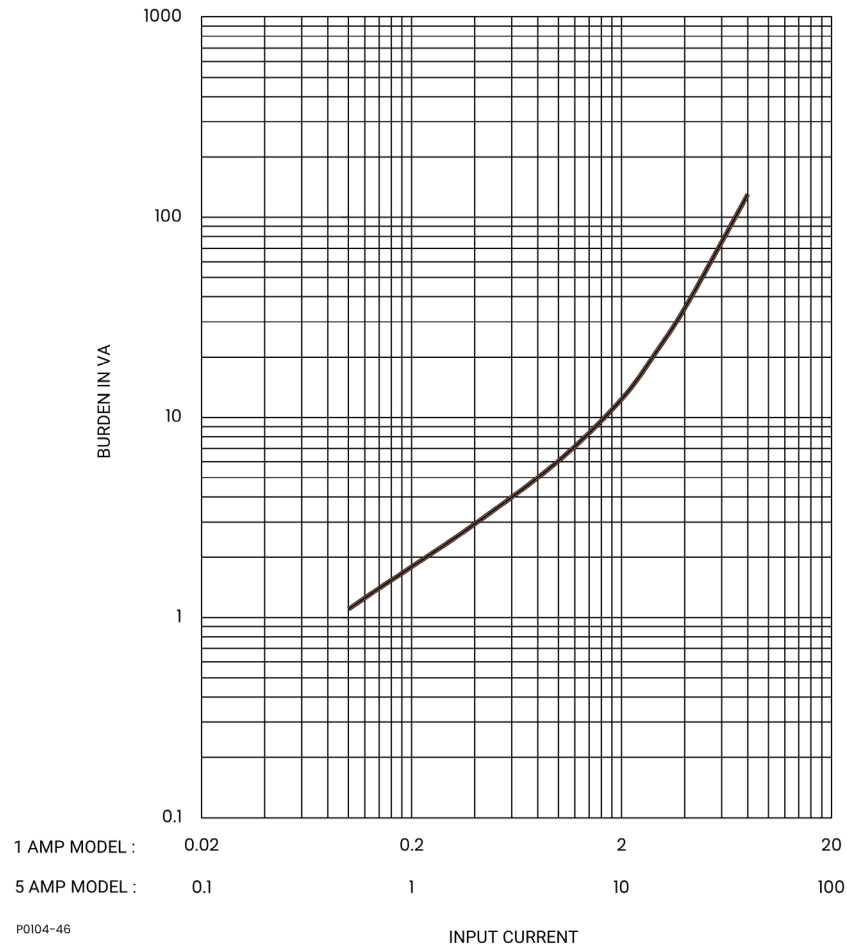

Figure 6-3. Burden Characteristics

Frequency Response

A change of ± 5 Hz from the nominal 50/60 Hz current causes $<0.5\%$ change in the current required for pickup.

Transient Response

$<10\%$ overreach with system time constants up to 40 ms.

Harmonic Rejection

Rejection of odd and even harmonics is illustrated in Figure 6-4.

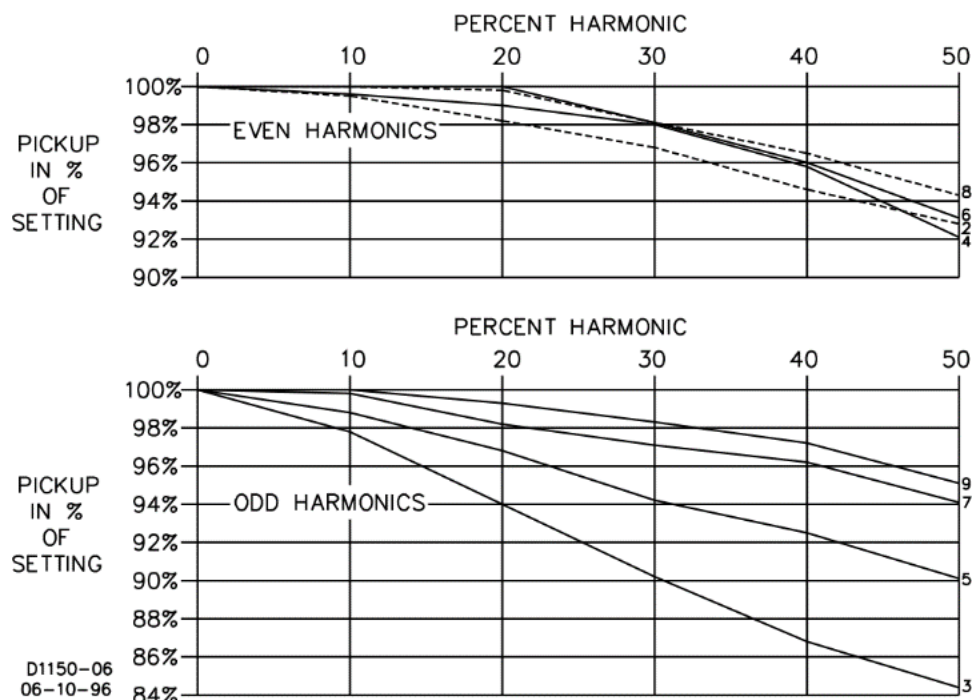

Figure 6-4. Harmonic Rejection

Target Indicators

A gravity-latched, manually-reset, current-operated target indicator is provided for the time-overcurrent (51) trip output and the instantaneous overcurrent A (50-A) trip output. A target indicator is not provided for the 50-B trip output. The level of trip circuit current required to operate each target is individually controlled by a circuit board jumper. See Section 2, *Controls and Indicators* for jumper locations and function assignments

Target Operate Current

- Jumper Position—Pins 1 and 2.....Must operate ≥ 2.25 A; must not operate < 900 mA. *
- Jumper Position—Pins 2 and 3.....Must operate ≥ 200 mA; must not operate < 80 mA. *

* See *Output Contacts* for the maximum acceptable levels of trip circuit currents.

Output Contacts

Output contacts are surge protected and rated as follows.

Resistive Ratings

- 120/240 Vac Make 30 amperes for 0.2 seconds, carry 7 amperes for 2 minutes, 3 amperes continuously, and break 5 amperes.
- 125/250 Vdc Make 30 amperes for 0.2 seconds, carry 7 amperes for 2 minutes, 3 amperes continuously, and break 0.3 ampere.

Inductive Ratings

- 120/240 Vac, 125/250 Vdc..... Make and carry 30 amperes for 0.2 seconds, carry 7 amperes for 2 minutes, 3 amperes continuously, and break 0.3 ampere. (L/R = 0.04).

Terminal Assignments

- 51 Element 1, 10
- 50-A Element 1, 10
- 50-B Element 2, 10

Type Tests

Isolation	IEEE C37.90 - 2005
Transient Surge	IEEE C37.90.1 - 2002
Radiated Interference	IEEE C37.90.2 - 2004
Electrostatic Discharge	IEEE C37.90.3 - 2001
Vibration	IEC 255-21-1
Shock and Bump	IEC 255-21-2

Environment

Operating Temperature	-40 to 70°C (-40 to 158°F)
Storage Temperature	-50 to 70°C (-58 to 158°F)

China RoHS

The following table serves as the declaration of hazardous substances for China in accordance with PRC standard SJ/T 11364-2014. The EFUP (Environment Friendly Use Period) for this product is 40 years.

PRODUCT: BE1-50/51B										
零件名称 Part Name	有害物质 Hazardous Substances									
	铅 Lead (Pb)	汞 Mercury (Hg)	镉 Cadmium (Cd)	六价铬 Hexavalent Chromium (Cr ⁶⁺)	多溴联苯 Polybrominated Biphenyls (PBB)	多溴二苯醚 Polybrominated Diphenyl Ethers (PBDE)	邻苯二甲 酸二丁酯 Dibutyl Phthalate (DBP)	邻苯二甲 酸丁苄酯 Benzyl butyl phthalate (BBP)	邻苯二甲 酸二酯 Bis(2- ethylhexyl) phthalate (BEHP)	邻苯二甲 酸二异丁 酯 Diisobutyl phthalate (DIBP)
金属零件 Metal parts	X	O	X	O	O	O	O	O	O	O
聚合物 Polymers	O	O	O	O	O	X	O	O	O	O
电子产品 Electronics	X	O	X	O	O	O	O	O	O	O
电缆和互连 配件 Cables & interconnect accessories	X	O	O	O	O	O	O	O	O	O
绝缘材料 Insulation material	O	O	O	O	O	O	O	O	O	O

本表格依据 SJ/T11364 的规定编制。

O: 表示该有害物质在该部件所有均质材料中的含量均在 GB/T 26572 规定的限量要求以下。

X: 表示该有害物质至少在该部件的某一均质材料中的含量超出 GB/T 26572 规定的限量要求。

This form was prepared according to the provisions of standard SJ/T11364.

O: Indicates that the hazardous substance content in all homogenous materials of this part is below the limit specified in standard GB/T 26252.

X: Indicates that the hazardous substance content in at least one of the homogenous materials of this part exceeds the limit specified in standard GB/T 26572.

Physical

Weight 6.1 lb (2.77 kg)

7 • Time Characteristic Curves

This section describes and defines the instantaneous overcurrent, time overcurrent, and integrating time reset characteristics of the BE1-50/51B-235 and BE1-50/51B-236 relays.

Instantaneous Overcurrent Characteristics

Timing

The instantaneous characteristic curves of the BE1-50/51B-235 and BE1-50/51B-236 relays are similar to standard electromechanical instantaneous units. However, the time to trip for applications where the initial sensing current is less than 400 mA may be slightly longer. This may occur on a very lightly loaded circuit or when the relay is providing ground protection and is connected to measure neutral current. Figure 7-1 shows the instantaneous characteristic curves for the maximum time to trip.

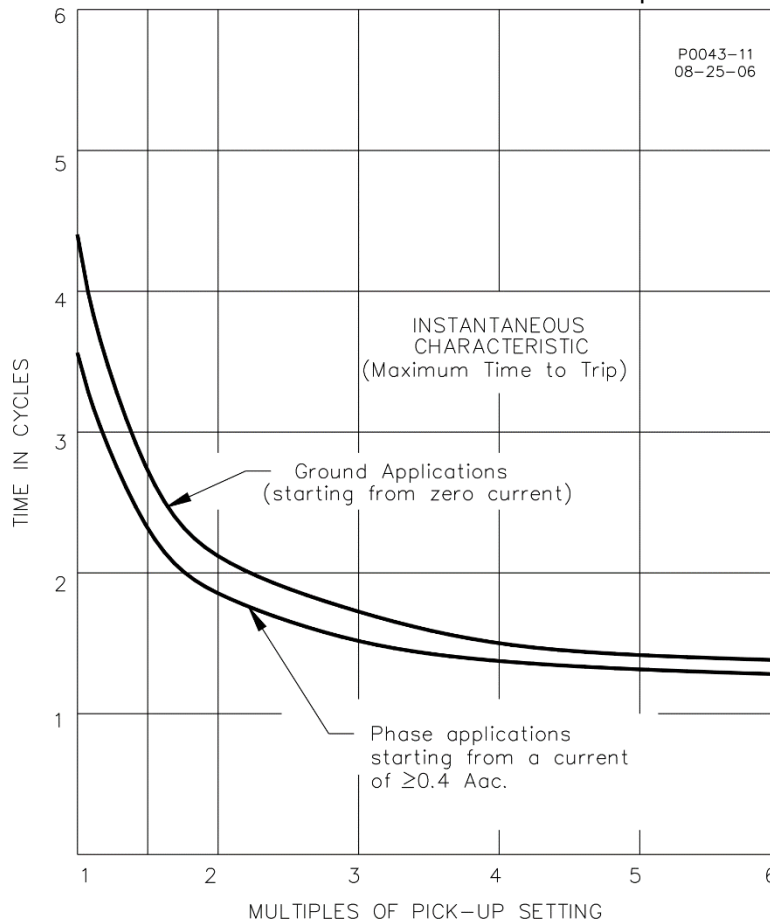

Figure 7-1. Instantaneous Characteristic Curves

The delay of the Instantaneous A (50-A) element can be set for no intentional delay (switch SW3-2 open) or an additional delay of 100 ms (SW3-2 closed). Figure 2-2 illustrates the location of SW3. The time delay of the 50-B element is not switch-selectable and is fixed at no intentional delay.

Pickup

The instantaneous elements of the BE1-50/51B-235 and BE1-50/51B-236 relays may be set lower than the instantaneous element in ABB CO relays and still have the same reach. This is because the BE1-50/51B-235 and BE1-50/51B-236 instantaneous elements effectively eliminate the fault current transient overreach components. When setting the BE1-50/51B-235 and BE1-50/51B-236 instantaneous elements, calculate the symmetrical value without any adder for transient overreach.

Time Overcurrent Characteristics

Nine inverse time functions and one fixed (definite) time function can be selected at the front panel. Curve types are identified by a letter designator. Available curve types are short inverse (S), long inverse (L), definite time (D), moderately inverse (M), inverse (I), very inverse (V), extremely inverse (E), BS142 inverse (B), and BS142 extremely inverse (C).

Inverse Time Functions

Characteristic curves for the inverse and definite time functions are defined by the following equation:

$$T_T = \frac{AD}{M^N - C} + BD + K$$

Where: T_T = time to trip in seconds
 D = time dial setting
 M = multiple of pickup setting
 A, B, C, N, K = constants for the particular curve

Characteristic Curve Groups

Either GE IAC or ABB CO characteristic curve groups are selected through switch SW3-3. (Refer to Figure 2-2 for the location of SW3.)

Characteristic Curve Constants

Tables 7-1 and 7-2 list the time characteristic curve constants used by the relay. Constants have been selected to conform to the characteristics of electromechanical relays over a range of pickup multiples from 1.3 to 40. Values of the constants are provided for use in PC relay setting applications. Timing accuracy is ± 1 cycle $\pm 2\%$ of time to trip.

Table 7-1. Time Characteristic Curve Constants with Switch SW3-3 Open (Off)

Curve Type	Similar To	Figure Number	Constants					
			A	B	C	N	K	R
S	CO-2	7-2	0.2663	0.03393	1.000	1.2969	0.028	0.500
L	CO-5	7-3	5.6143	2.18592	1.000	1.0000	0.028	15.750
D	CO-6	7-4	0.4794	0.21359	1.000	1.5625	0.028	0.875
M	CO-7	7-5	0.3022	0.12840	1.000	0.5000	0.028	1.750
I	CO-8	7-6	8.9341	0.17966	1.000	2.0938	0.028	9.000
V	CO-9	7-7	5.4678	0.10814	1.000	2.0469	0.028	5.500
E	CO-11	7-8	7.7624	0.02758	1.000	2.0938	0.028	7.750
B	BS142-B*	7-9	1.4636	0.00000	1.000	1.0469	0.028	3.250
C	BS142-C*	7-10	8.2506	0.00000	1.000	2.0469	0.028	8.000
F	None†	None	0.0000	1.00000	0.000	0.0000	0.000	1.000

* Curves B and C are defined in British Standard BS142 and IEC 255-4 (International Electrotechnical Commission).

† Fixed time from 0.1 to 9.9 seconds.

Table 7-2. Time Characteristic Curve Constants with Switch SW3-3 Closed (On)

Curve Type	Similar To	Figure Number	Constants					
			A	B	C	N	K	R
S	IAC 55	7-11	0.0286	0.0208	1.000	0.9844	0.028	0.0940
L	IAC 66	7-12	2.3955	0.00002	1.000	0.3125	0.028	7.8001
D	CO-6	7-4	0.4797	0.21359	1.000	1.5625	0.028	0.8750
M	CO-7	7-5	0.3022	0.12840	1.000	0.5000	0.028	1.7500
I	IAC 51	7-13	0.2747	0.1042	1.000	0.4375	0.028	0.8868
V	IAC 53	7-14	4.4309	0.0991	1.000	1.9531	0.028	5.8231
E	IAC 77	7-15	4.9883	0.0129	1.000	2.0469	0.028	4.7742
B	BS142-B*	7-9	1.4636	0.00000	1.000	1.0469	0.028	3.2500
C	BS142-C*	7-10	8.2506	0.00000	1.000	2.0469	0.028	8.0000
F	None†	None	0.0000	1.00000	0.000	0.0000	0.000	1.0000

* Curves B and C are defined in British Standard BS142 and IEC 255-4 (International Electrotechnical Commission).

† Fixed time from 0.1 to 9.9 seconds.

Characteristic Curves

Figures 7-2 through 7-15 illustrate the BE1-50/51B-235 and BE1-50/51B-236 time overcurrent characteristic curves.

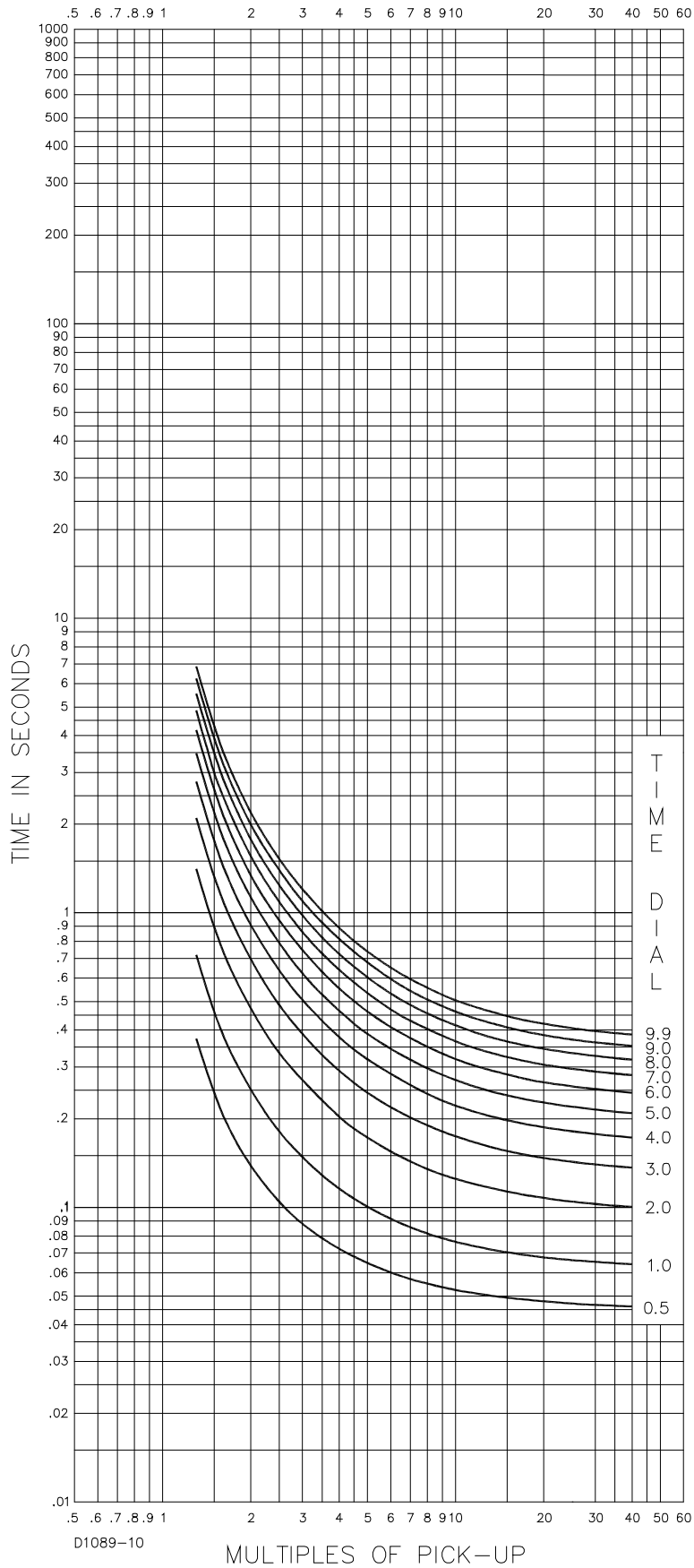

Figure 7-2. Short Inverse (S) Time Characteristic Curve (SW3-3 Off, Similar to ABB CO-2)

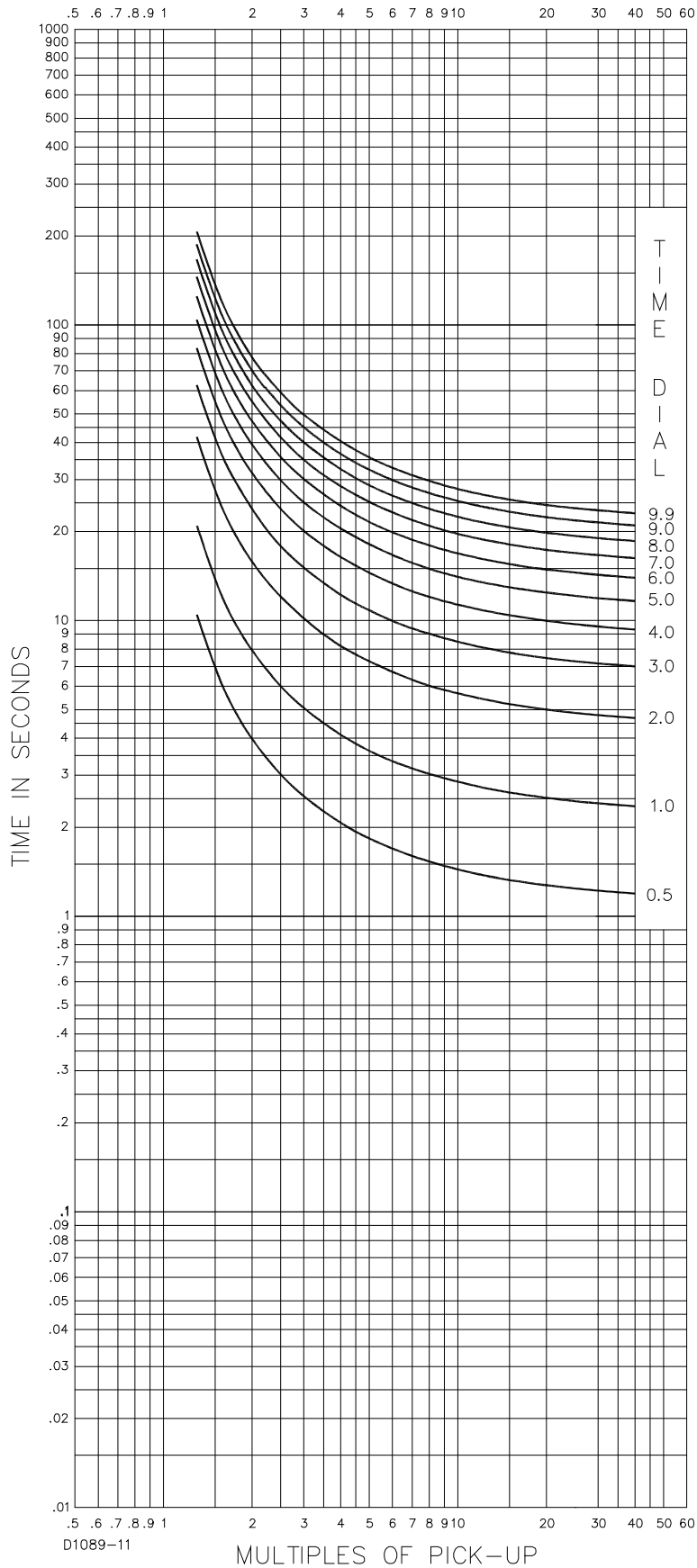

Figure 7-3. Long Inverse (L) Time Characteristic Curve (SW3-3 Off, Similar to ABB CO-5)

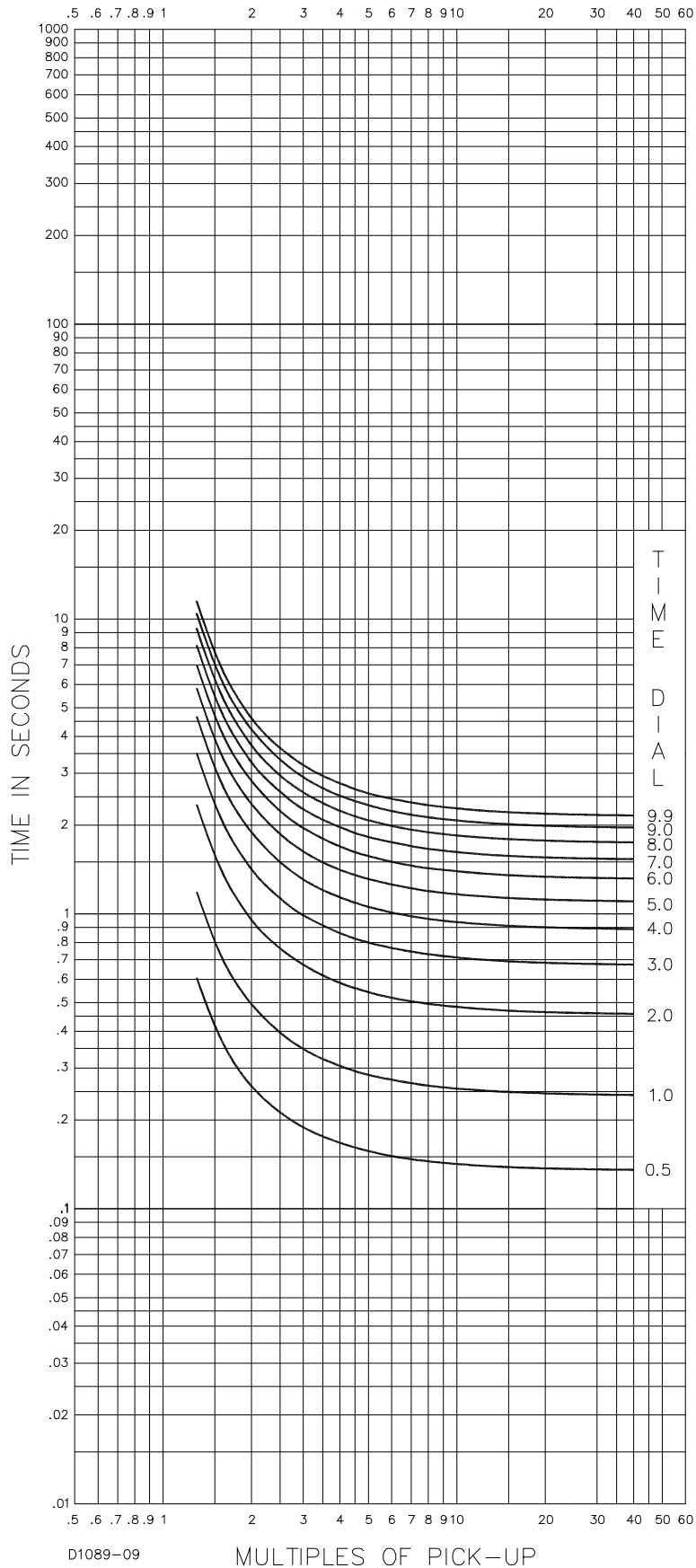

Figure 7-4. Definite Time (D) Time Characteristic Curve (Similar to ABB CO-6)

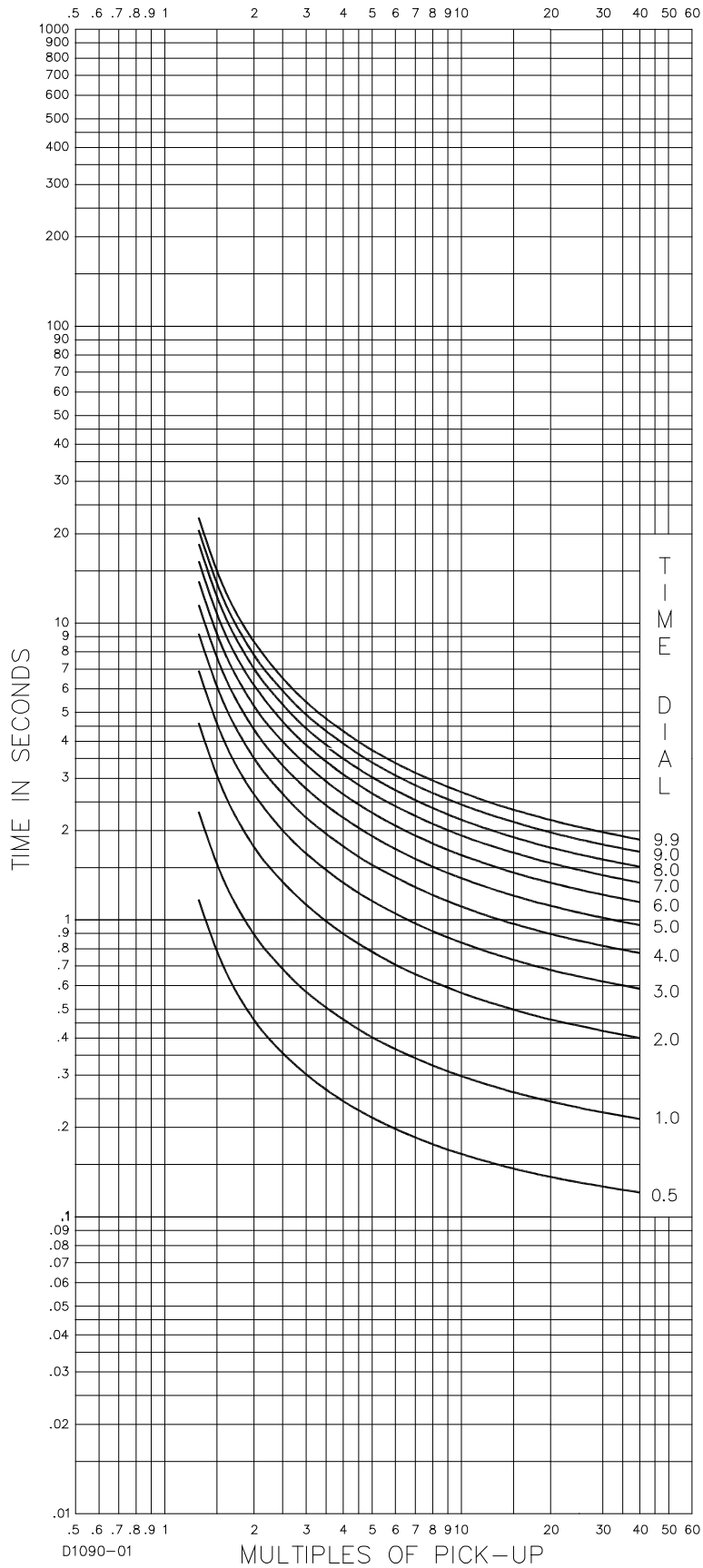

Figure 7-5. Moderately Inverse (M) Time Characteristic Curve (Similar to ABB CO-7)

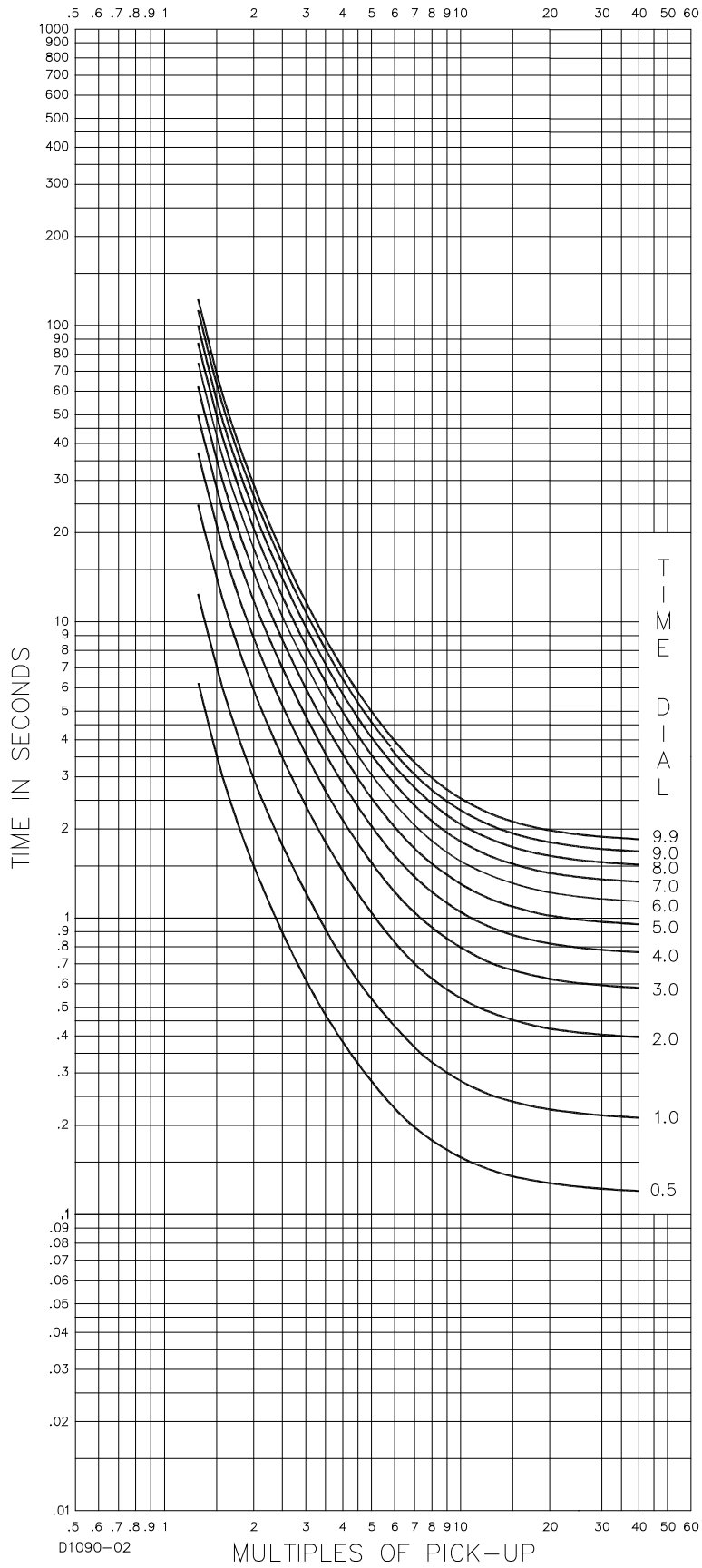

Figure 7-6. Inverse (I) Time Characteristic Curve (SW3-3 Off, Similar to ABB CO-8)

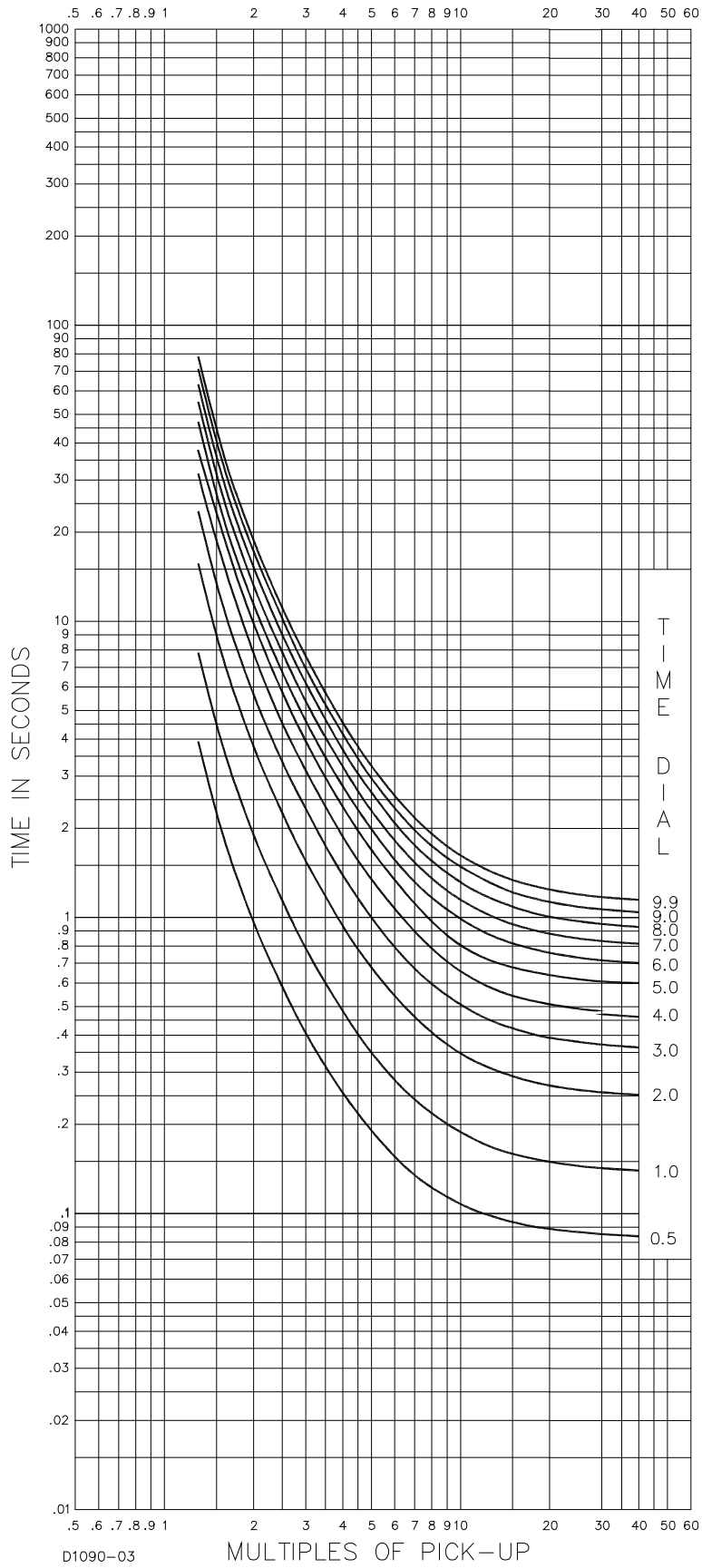

Figure 7-7. Very Inverse (V) Time Characteristic Curve (SW3-3 Off, Similar to ABB CO-9)

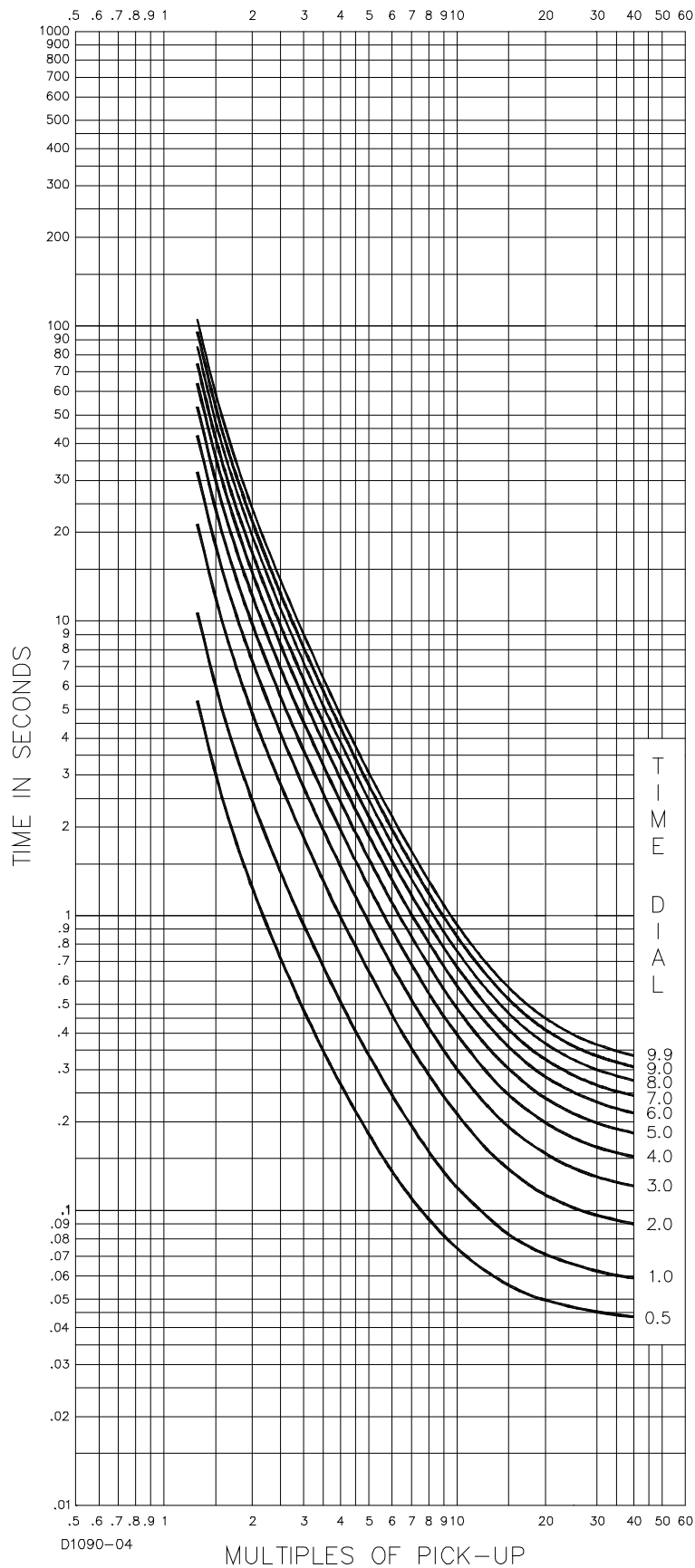

Figure 7-8. Extremely Inverse (E) Time Characteristic Curve (SW3-3 Off, Similar to ABB CO-11)

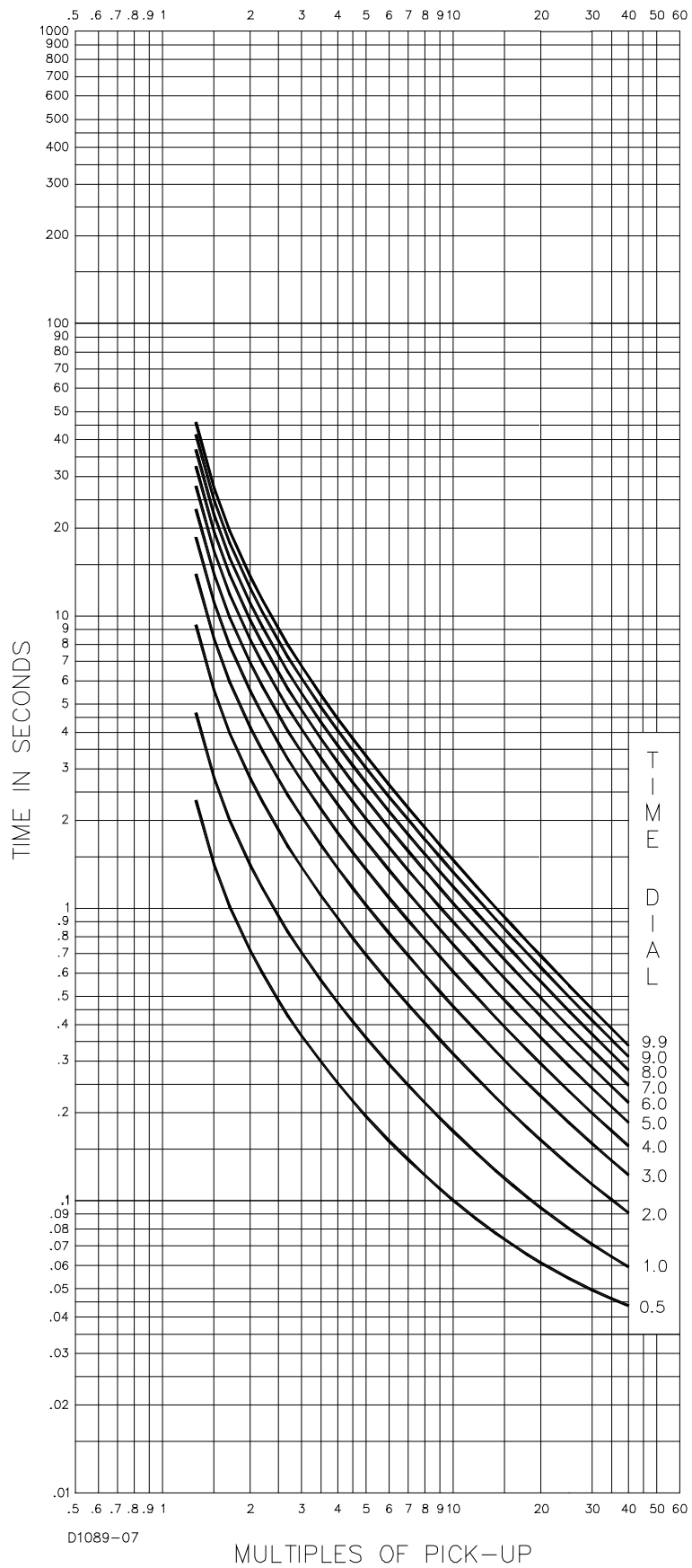

Figure 7-9. BS142 Very Inverse (BS142-B) Time Characteristic Curve

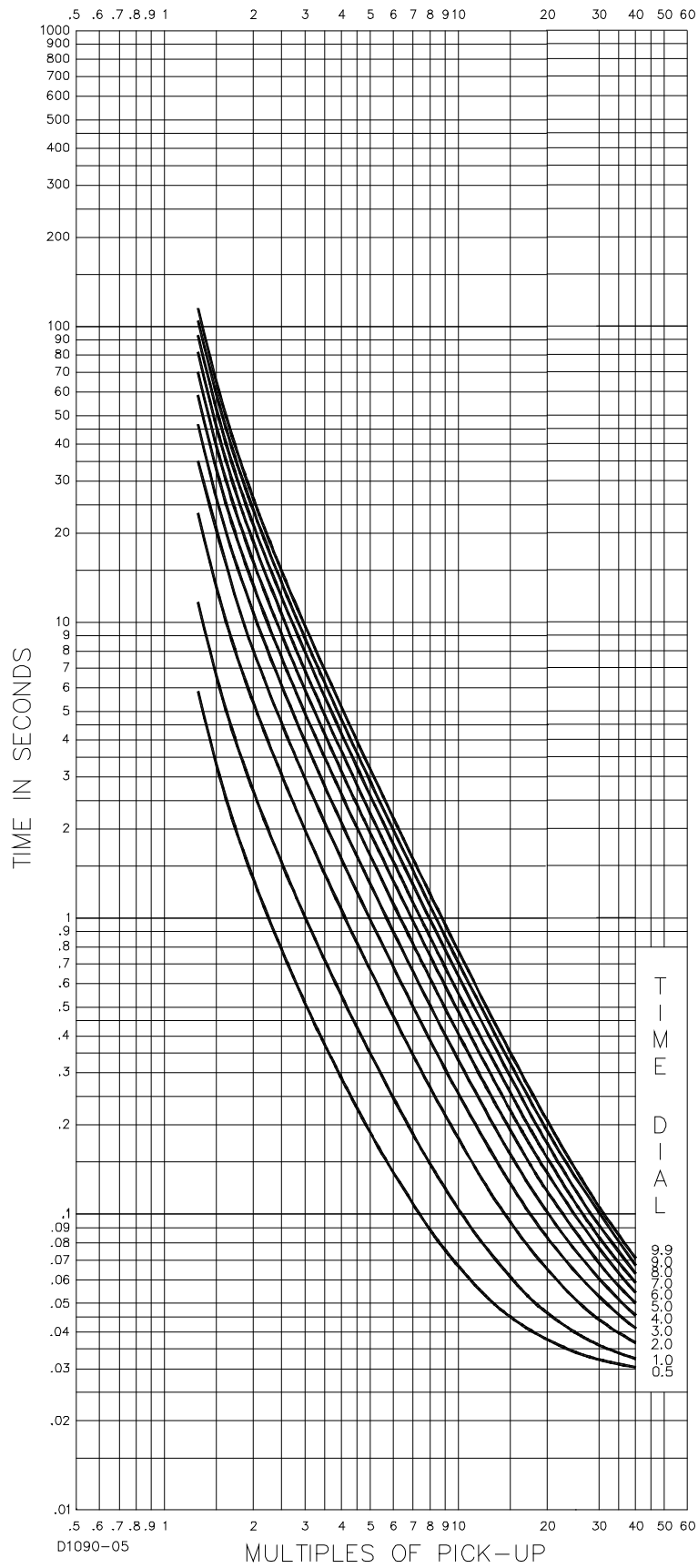

Figure 7-10. BS142 Extremely Inverse (BS142-C) Time Characteristic Curve

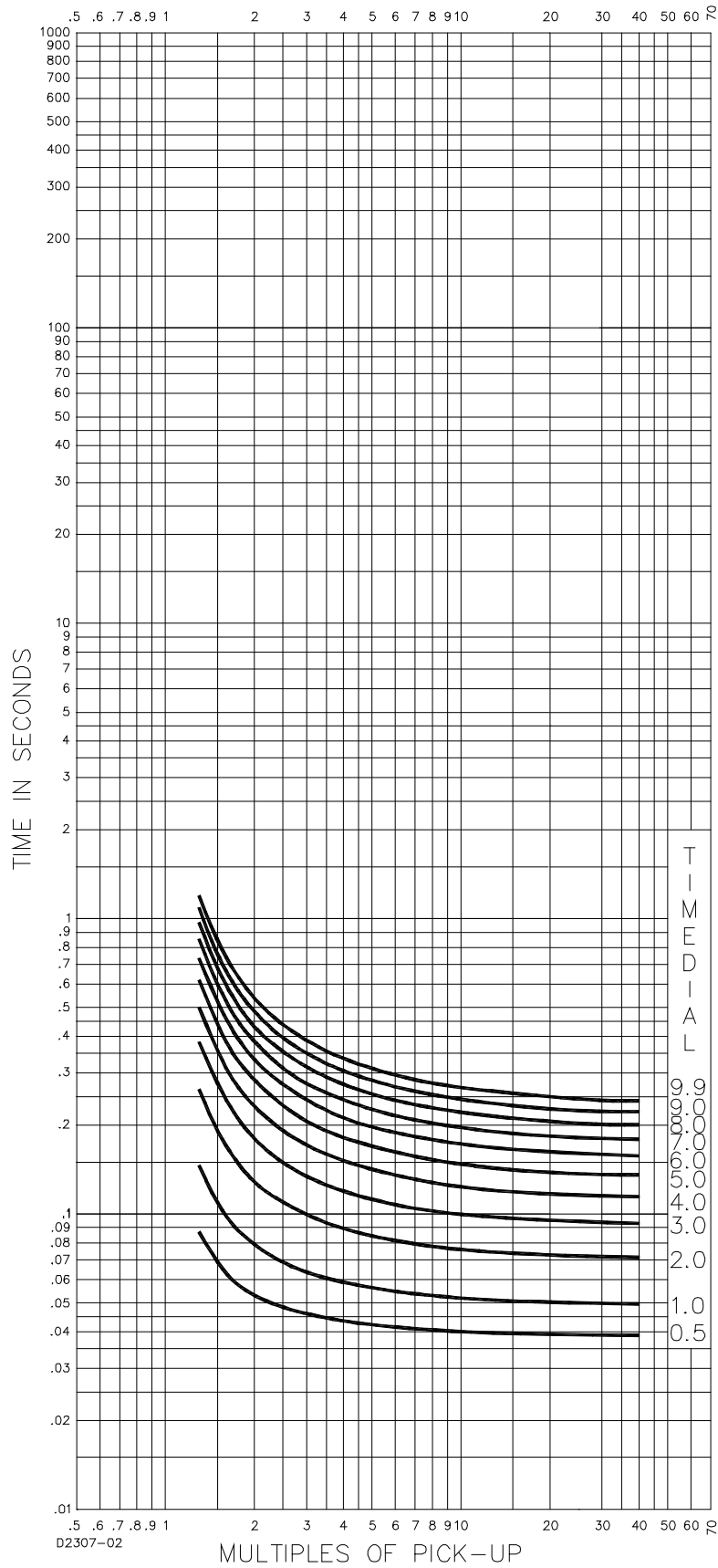

Figure 7-11. Short Inverse (S2) Time Characteristic Curve (SW3-3 On, Similar to GE IAC 55)

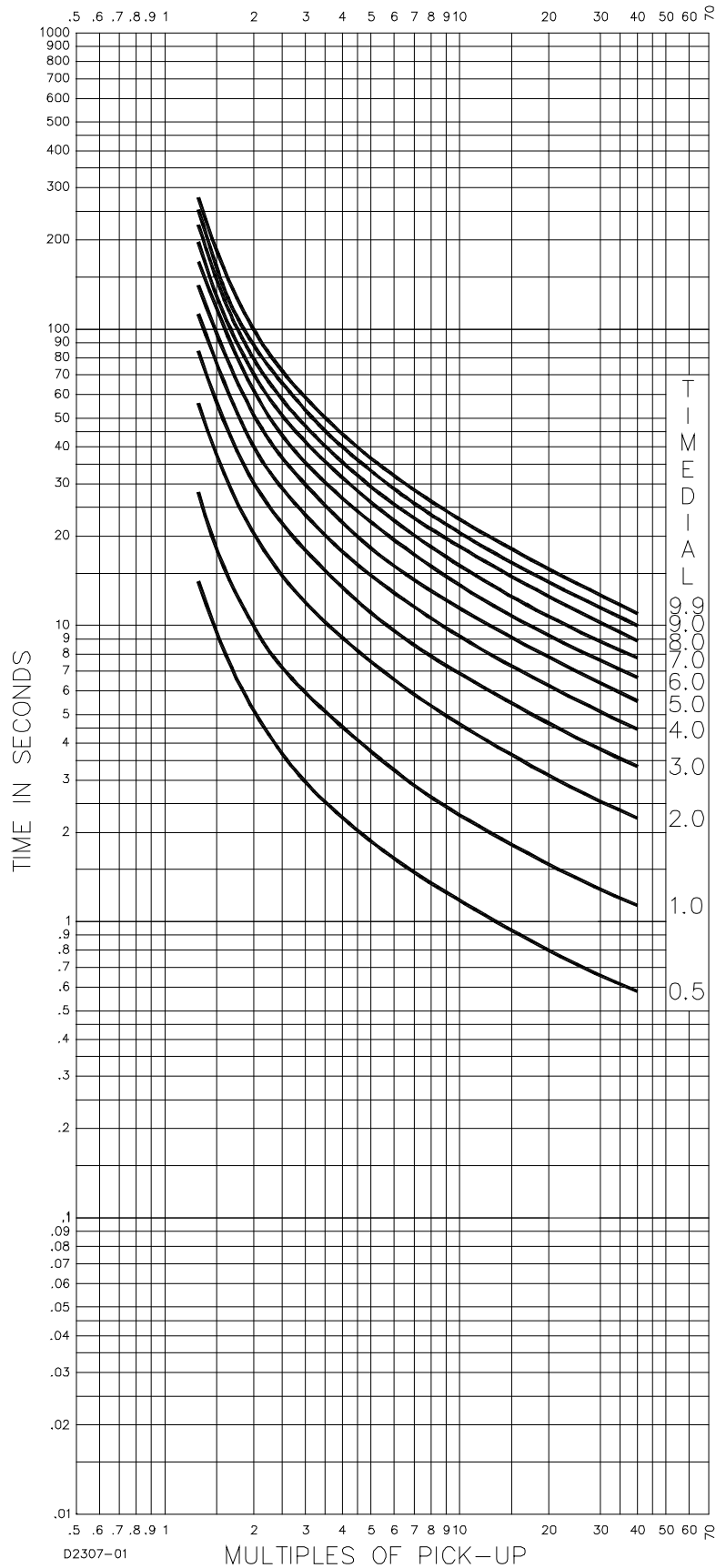

Figure 7-12. Long Inverse (L2) Time Characteristic Curve (SW3-3 On, Similar to GE IAC 66)

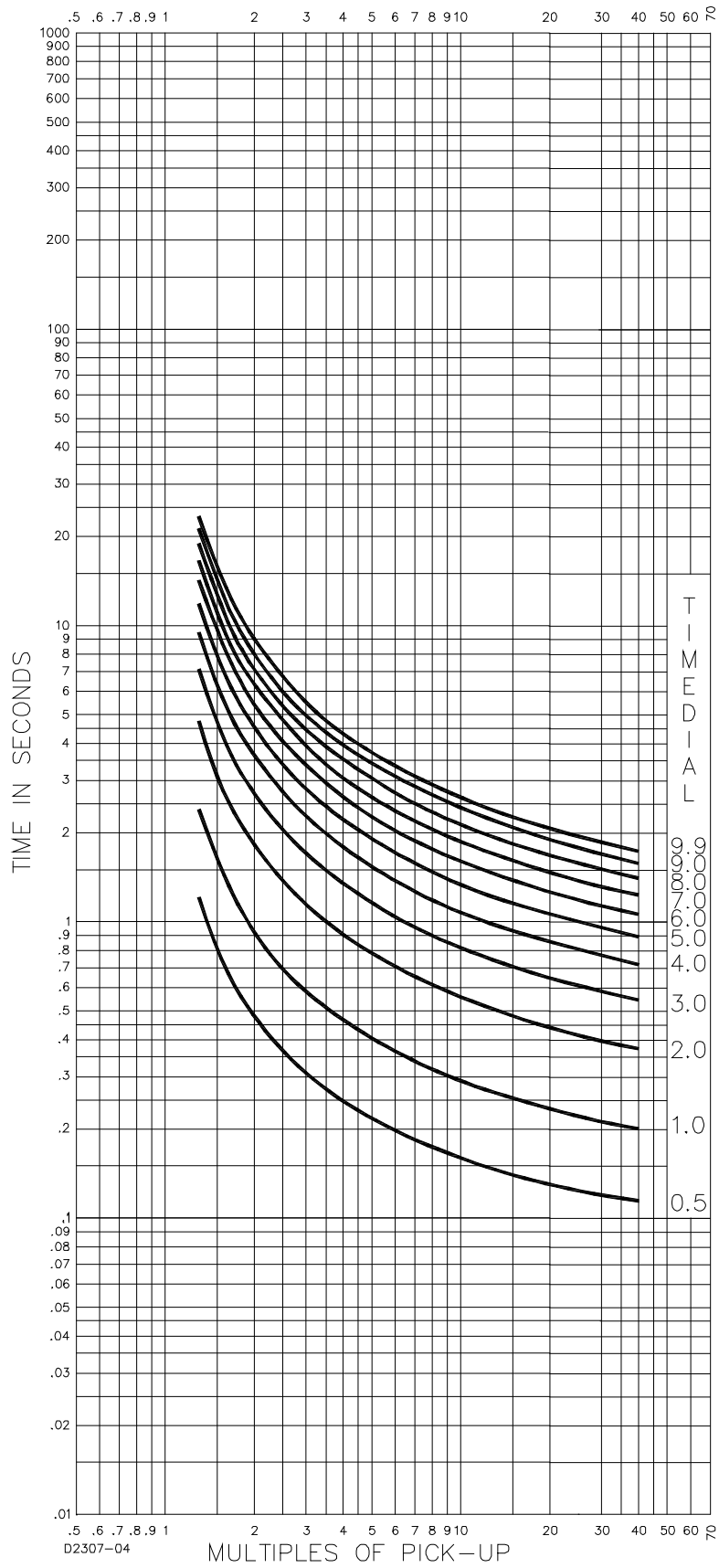

Figure 7-13. Inverse (I2) Time Characteristic Curve (SW3-3 On, Similar to GE IAC 51)

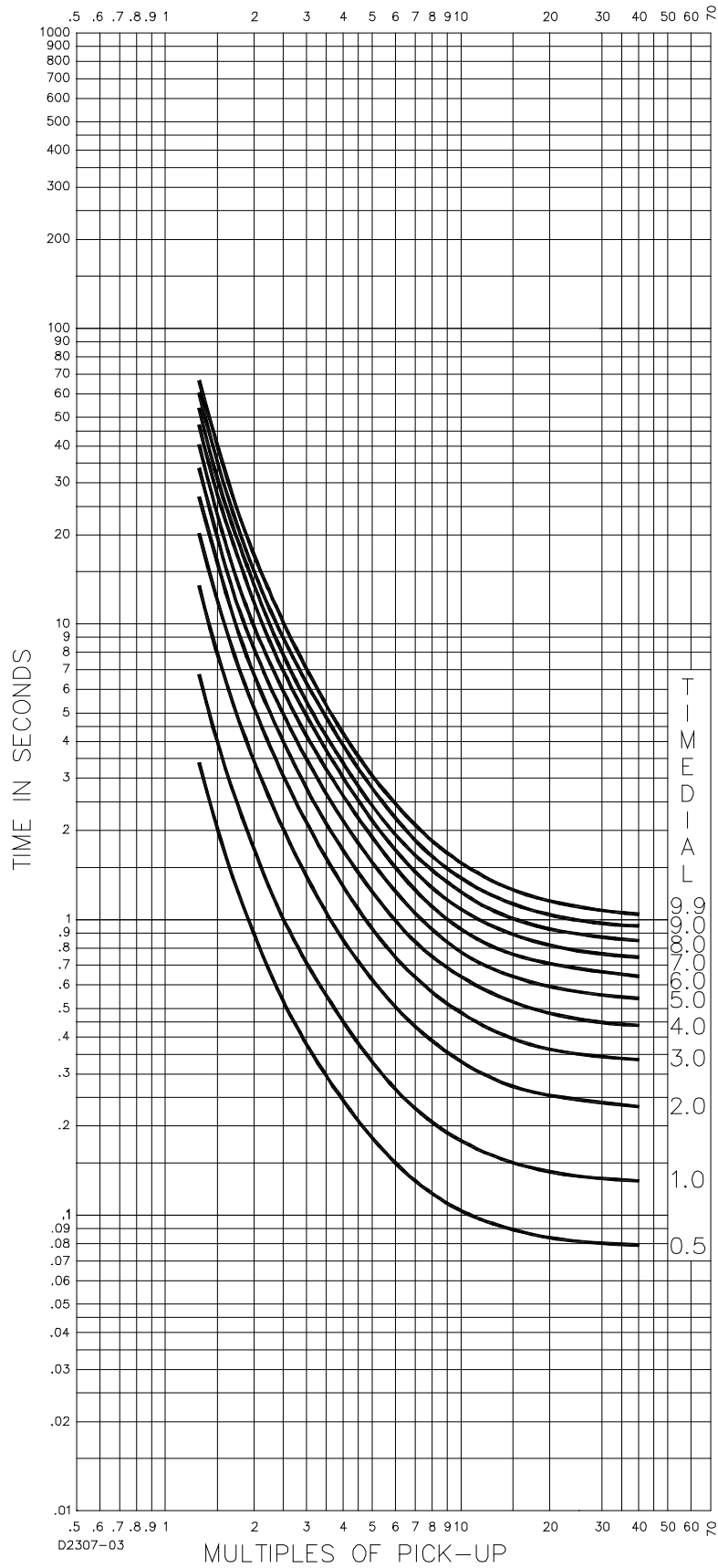

Figure 7-14. Very Inverse (V2) Time Characteristic Curve (SW3-3 On, Similar to GE IAC 53)

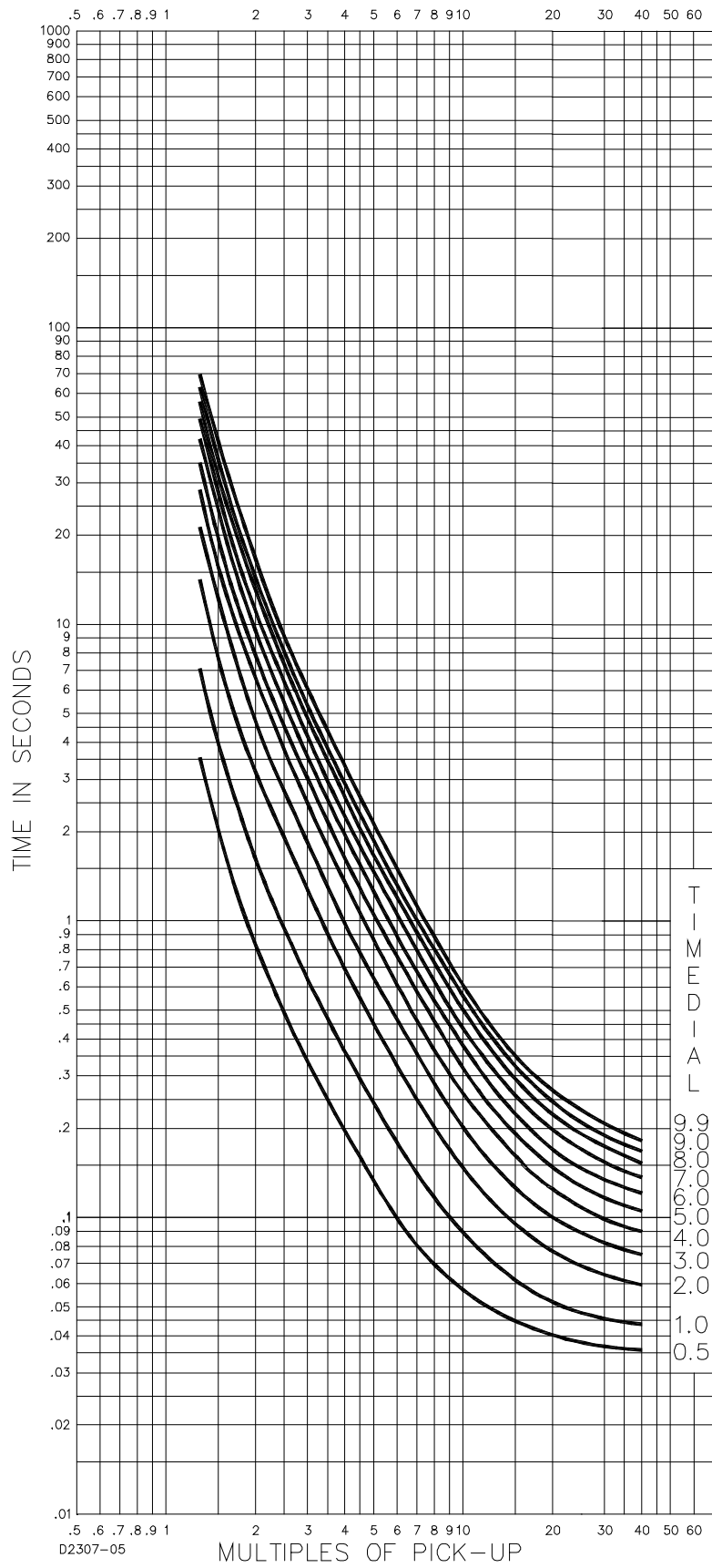

Figure 7-15. Extremely Inverse (E2) Time Characteristic Curve (SW3-3 On, Similar to GE IAC 77)

Integrating Time Reset Characteristic

The relay can be user-configured for integrating or instantaneous type reset.

Integrating reset simulates the disk reset of electromechanical relays and begins when the current decreases below 95% of pickup. BE1-50/51B-235 and BE1-50/51B-236 relays provide the integrating reset function even when input current decreases to zero.

Integrating reset characteristics are defined by the following equation and are illustrated in Figure 7-16. See Table 7-1 and 7-2 for the equation constants.

$$T_R = \frac{RD}{M^2 - 1}$$

Where: T_R = time to reset in seconds
 R = constant for the particular curve
 D = time dial setting
 M = current in multiples of pickup setting during reset

Time characteristic curve equation:

$$T_T = \frac{AD}{M^N - C} + BD + K = \text{Time to Trip}$$

Where: D = time dial setting
 M = multiple of pickup setting

Reset characteristic curve equation:

$$T_R = \frac{RD}{M^2 - 1} = \text{Time to Reset}$$

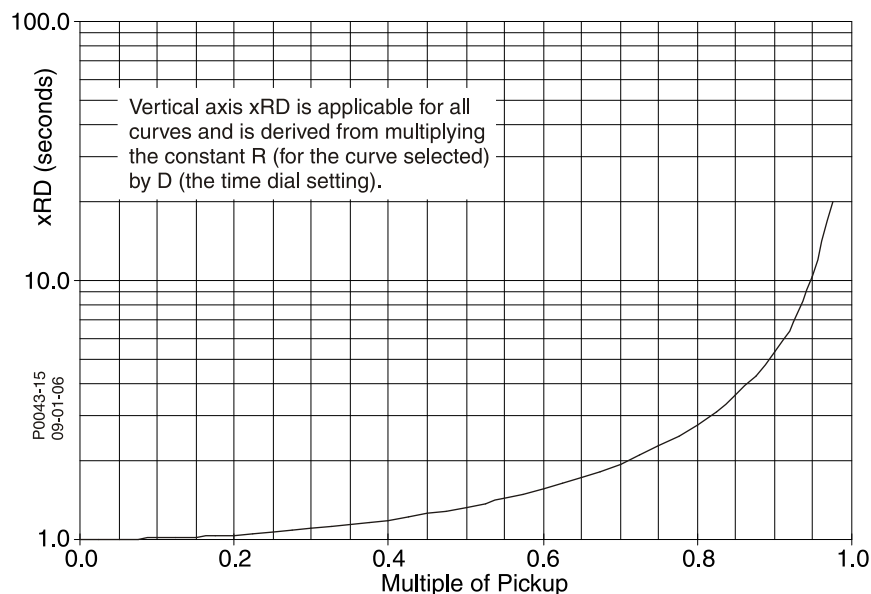

Figure 7-16. Integrating Reset Characteristic Curve

Instantaneous Reset

Reset occurs within 16 ms of when the current decreases to 95% of the pickup level.



Highland, Illinois USA
Tel: +1 618.654.2341
Fax: +1 618.654.2351
email: info@basler.com

Suzhou, P.R. China
Tel: +86 512.8227.2888
Fax: +86 512.8227.2887
email: chinainfo@basler.com